

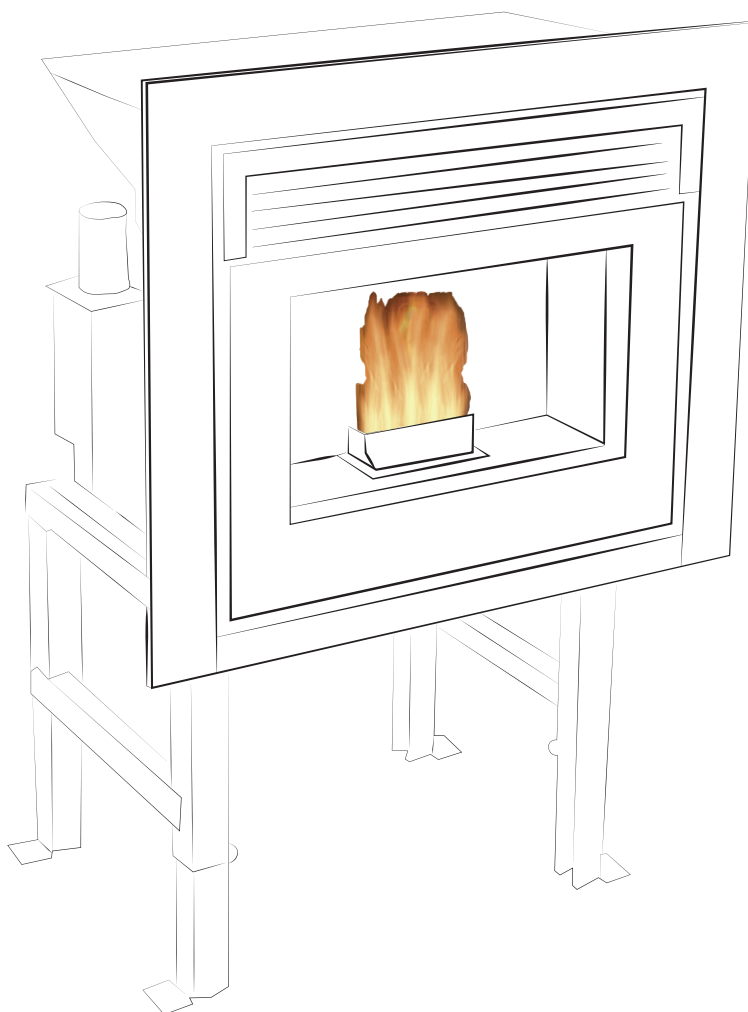

Calidez de *Vida*

MANUAL FOR THE USER AND INSTALLATION

INSERTABLE RANGE





We thank you for choosing us

The Ferlux wood pellet fireplace is a heating system that has been manufactured with the most advanced technology and a high level of quality, which allows you to enjoy the extraordinary feeling of a fire in total safety.

- We would ask you to read this manual closely because it contains important instructions regarding safety for installation, use, and maintenance.
- This manual, along with the documentation supplied, must be kept in a place that is easy and quick to access.
- Installation of FERLUX air heaters must be performed solely by authorised personnel who follow the instructions from the manufacturer and in accordance with any regulations in force.
- The manufacturer is not responsible for any possible damage that could be caused by the incorrect installation or handling of the unit.

INDEX

1. TAKING CARE OF THE MANUAL AND HOW TO CONSULT IT.....	6
2. GENERAL WARNINGS AND SAFETY.....	7
2.1. LEGAL WARRANTY.....	8
2.2. TECHNICAL ASSISTANCE.....	8
2.3. SPARE PARTS.....	8
3. TECHNICAL INFORMATION.....	9
4. FUEL.....	10
4.1. WHAT ARE WOOD PELLETS?.....	10
4.2. PROPERTIES OF WOOD PELLETS.....	10
4.3. STORAGE OF WOOD PELLETS.....	11
4.4. STOVE SUPPLY.....	11
5. INSTRUCTIONS FOR INSTALLATION.....	12
5.1. UNPACKING.....	12
5.2. PREVENTION OF DOMESTIC FIRES.....	12
5.2.1. PROTECTING THE FLOOR.....	12
5.2.2. MINIMUM SAFETY DISTANCES.....	12
5.2.3. MEASUREMENTS TO PIERCE BUILDING ENVELOPES.....	13
5.3. SMOKE DUCTING OR CHIMNEY.....	13
5.3.1. GENERAL BACKGROUND.....	14
5.3.2. CALCULATING THE EXHAUST SMOKE DUCTING.....	14
5.3.3. INSTALLATION IN TRADITIONAL-TYPE CHIMNEY.....	16
5.3.4. EXTERIOR STRETCH OF THE CHIMNEY.....	16
5.3.5. CAPPING SMOKE OUTLETS.....	17
5.4. VENTILATION AND AIR INTAKE.....	17
5.5. ELECTRICAL CONNECTION.....	20
6. INSTRUCTIONS WHEN USING THE CONTROL PANEL.....	20
6.1. MENÚ LEVEL 1.....	22
6.1.1. INFORMATION.....	22
6.1.2. REGULATION THE POWER.....	23
6.1.3. REGULATION DE ROOM TEMPERATURE.....	23
6.1.4. RESET ERRORS, TURNING THE HEATER ON AND OFF.....	24
6.1.5. LOADING THE PELLET SCREW.....	24

6.2. MENÚ LEVEL 2.....	25
6.2.1. [rAir] REGULATION OF THE FAN.....	25
6.2.2. [Cron] PROGRAMMING SCHEDULES.....	26
6.2.3. [oroL] CLOCK.....	30
6.2.4. [tELE] REMOTE CONTROL.....	30
6.2.5. [rCLr] TECHNICAL MENU 1.....	31
6.2.6. [tPAr] TECHNICAL MENU 2.....	31
7. USE AND FUNCTIONALITY OF THE HEATER.....	32
7.1. ADVICE AND CAUTIONS.....	32
7.2. FIRST LIGHTING.....	32
7.3. STATES OF FUNCTIONALITY.....	33
7.3.1. LIGHTING.....	33
7.3.2. NORMAL HEATER OPERATION.....	33
7.3.3. HEATER OFF.....	34
7.3.4. MODULATION (“MOD”).....	34
7.3.5. STANDBY.....	34
7.3.6. OFF.....	34
7.3.7. RECOVERY OF THE IGNITION (“REC”).....	35
8. MAINTENANCE AND CLEANING.....	35
8.1. CLEANING THE BRAZIER AND BRAZIER HOLDER.....	36
8.2. CLEANING THE ASH DRAWER.....	37
8.3. CLEANING THE INTERIOR OF THE COMBUSTION CHAMBER.....	37
8.4. CLEANING THE GLASS.....	39
8.5. UNPRESS THE DOOR CLOSURE CORD.....	39
9. PROBLEMS, MESSAGES, ERRORS, AND SOLUTIONS.....	40
9.1. PROBLEMS.....	40
9.2. MESSAGES.....	41
9.3. ERRORS AND SOLUTIONS.....	43
ANNEXED.....	46
ASSEMBLING THE TABLE WITH LEGS AT DIFFERENT HEIGHTS.....	46
REGULATION OF THE LEGS AT DIFFERENT HEIGHTS.....	47
MOUNTING ADDITIONAL CHARGING TUBE ON INSERTABLE.....	47
ASSEMBLY OF ADDITIONAL CHARGING TUBE IN CLADDING.....	49
COMMERCIAL WARRANTY.....	50
GENERAL CONDITIONS OF THIS COMMERCIAL WARRANTY AGREEMENT.....	52

1. TAKING CARE OF THE MANUAL AND HOW TO CONSULT IT

Keep this manual safe and store it in an accessible location close to the unit.

In the event that this manual is lost or becomes difficult to read, ask the installer for a copy or enquire directly with the manufacturer, specifying the identifying details of the product.

The proper functioning of the heater depends, to a great extent, on the user knowing how it works and knowing what to do at all times. This manual has a contents page on pages four and five so that you can easily find the section to consult to resolve any questions or issues that may arise.

When you read or consult this manual, you must take the following into account:

It is important to pay special attention to the texts written in 'bold'



In some cases, capital letters may be used and/or the size of the font will be increased in order to draw your attention to the paragraph.

The text in 'italics' is used when the issue being handled mentions other paragraphs in this same manual, or for eventual clarifications.

In some cases, two or more of the styles above could be combined. This would be the case when we refer to the reading of other chapters in order to supplement or refer to information.

Example: (see chapter '7. USE AND FUNCTIONALITY OF THE HEATER')

SYMBOLS

SYMBOL	MEANING	TYPE OF INFORMATION SHOWN
	INFORMATION	This is used to provide information that will be very useful to the user, help them improve the functionality of their heater, and/or better understand certain situations and know how to react.
	ATTENTION	This is used to provide information regarding something obligatory or prohibited and when failing to do something may have serious consequences.

2. GENERAL WARNINGS AND SAFETY

The installation must be carried out by an authorised person who must provide the purchaser with a declaration for the installation in which they accept full responsibility for the final installation.

In the same way, the product must be started up by an authorised person who must provide the purchaser with a product start-up document in which they accept full responsibility for the final installation and operation of the installed unit.

FERLUX shall not bear any responsibility in the event that these precautions are shown to have not been met.

All national and local regulations, as well as European regulations, must be satisfied when the unit is being installed. All national and local regulations, as well as European regulations, must be satisfied when the unit is operational.

FERLUX S.A. accepts no responsibility in the event of the aforementioned requirements failing to be met.

Our units are manufactured and tested, with all their parts being monitored, in line with the safety directives of the European Union, which aim to protect both the user as well as the installer against possible accidents. Technical personnel are strongly urged to pay close attention to the connections, wiring, and electrical voltage when they are required to perform any kind of operation on the unit.

The manufacturer is not liable for any responsibility, whether contractual or extra-contractual, for damages caused to persons, animals, or objects due to errors in the installation, configuration, and/or maintenance.

This heater must only be used for the purpose for which it was specifically designed.

Certain extreme weather conditions, such as strong winds, hail, or the risk of frost, could mean that the chimney flue is insufficient. Due to the potential risk of back-puffing smoke, use of the unit in these circumstances is not recommended. This cannot be considered as a defect in the unit or as unsatisfactory functionality.

For your safety, you must bear in mind that:

- The user of the heater must be a responsible adult. This unit has not been designed to be used by people whose physical, sensorial, or cognitive capabilities are limited or who have no experience or expertise in the matter. Children must be watched closely and taught how to behave in order to guarantee that they do not play with the unit or come into contact with surfaces that are hot when in operation.
- The connection to the power supply and its corresponding power outlet must be easily accessible at all times. It is absolutely prohibited to make the unit operate with a damaged power cable. If the power cable is damaged, it must be immediately replaced.
- Do not disconnect the plug from the power outlet when the unit is turned on.
- The door on the heater must always remain closed when the heater is in operation.
- Avoid coming into contact with areas of the unit that reach a high temperature when in operation, especially with the glass and the door.
- Following an extended period of disuse, before turning the unit on, check that there are no obstructions in the smoke extraction ducting ¹.

¹ In extreme cases or breakdown, safety systems may intervene. In this case, contact the Technical Support Service. DO NOT DEACTIVATE THE SAFETY SYSTEMS.



!!!ATTENTION!!!

THE INSTALLATION MUST BE CARRIED OUT BY AN AUTHORISED PERSON WHO MUST PROVIDE THE PURCHASER WITH A DECLARATION OF CONFORMITY FOR THE INSTALLATION IN WHICH THEY ACCEPT FULL RESPONSIBILITY FOR THE FINAL INSTALLATION AND, CONSEQUENTLY, THE PROPER OPERATION OF THE INSTALLED UNIT. FERLUX SHALL NOT BEAR ANY RESPONSIBILITY IN THE EVENT THAT THESE PRECAUTIONS ARE SHOWN TO HAVE NOT BEEN MET.

2.1 LEGAL WARRANTY

In order to be able to enjoy the legal warranty in accordance with EEC Directive 1994/44EC, a user must fully comply with all of the instructions contained in this manual, and especially:

- Must always act within the limits of use of the heater.
- Must always perform ongoing and thorough maintenance.
- Must authorise the use of the heater only to persons of proven capacity, attitude, and who are properly trained for such a task.

The manufacturer accepts no responsibility, legal or penal, directly or indirectly, for:

- An installation that is not in full compliance with the regulations in force in the country as well as safety directives.
- Non-compliance on the part of unqualified and/or untrained personnel.
- Usage not in compliance with safety directives.
- Modifications and repairs not authorised by the Manufacturer and made to the unit.
- Use of spare parts that are not original or are not specified for that specific model of heater.
- Insufficient maintenance.
- Exceptional circumstances.

2.2 TECHNICAL ASSISTANCE

FERLUX is capable of providing a solution to any technical problem regarding the use and maintenance of the unit at any point during its operational life.

2.3 SPARE PARTS

Only use original spare parts.

Do not wait for parts to be damaged before proceeding to replace them. Replacing a worn component before it breaks helps prevent accidents caused by the sudden breaking of these components, which could cause harm to people or objects.

3. TECHNICAL DATA

The data plate or label is located on the rear part of the unit and shows all the characteristic data for the unit, including the details of the manufacturer, the serial number, and the CE marking.

A label that is missing or obscured makes the tasks of installing and repairing the unit more difficult because it may not be possible to identify the product. In the event of it becoming damaged, request a copy from the Technical Support Service.

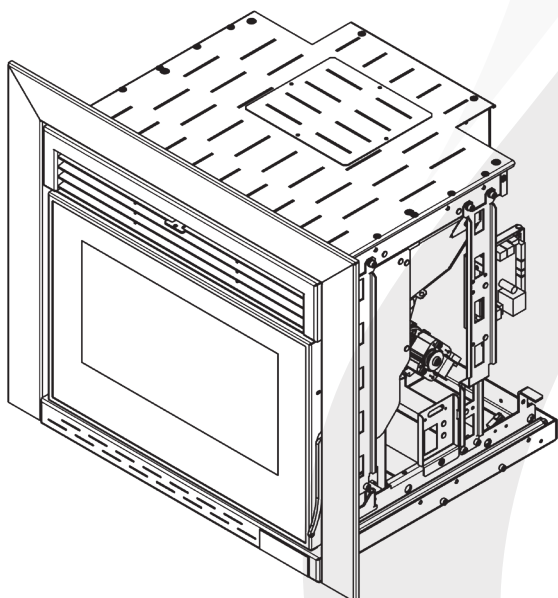

P ROPERTIES		ULYSES 8	ULYSES 10
Weight	Kg.	105	105
Height	mm	681	681
Width	mm	771	771
Depth	mm	587	587
Diameter of smoke outlet	mm	80	80
Diameter of primary air inlet	mm	40	40
Heatable volume	m ³	210	245
Maximum useful thermal power	kW	8,5	10,2
Maximum performance	%	90	88
Minimum useful thermal power	kW	3,4	3,4
Minimum performance	%	94	94
Minimum hourly fuel consumption	kg/h	0,7	0,7
Maximum hourly fuel consumption	kg/h	1,9	2,3
Tank capacity	kg	13	13
Fuel		PELLET	
Recommended chimney flue	Pa	10-12	10-12
Nominal electrical power turned on	W	366	370
Nominal electrical power (power 1-5)	W	66	70
Nominal voltage	V	220-240	220-240
Nominal frequency	Hz	50	50
Average temperature of gases at N.T.P. *	°C	143	185
Average temperature of gases at R.T.P. **	°C	67	67
Average concentration of CO ₂ at N.T.P. *	%	9,68	10,6
Average concentration of CO ₂ at R.T.P. **	%	6,24	6,24
Mass flow rate of smoke at N.T.P. *	g/s	7,5	8,3
Mass flow rate of smoke at R.T.P. **	g/s	26	26
CO concentration 13% O ₂ at N.T.P. *	%	0,02	0,02
CO concentration 13% O ₂ at R.T.P. **	%	0,03	0,03

* P.T.N. _____ Nominal thermal power
 ** P.T.R. _____ Reduced thermal power

MODEL ULYSES 8/10 KW

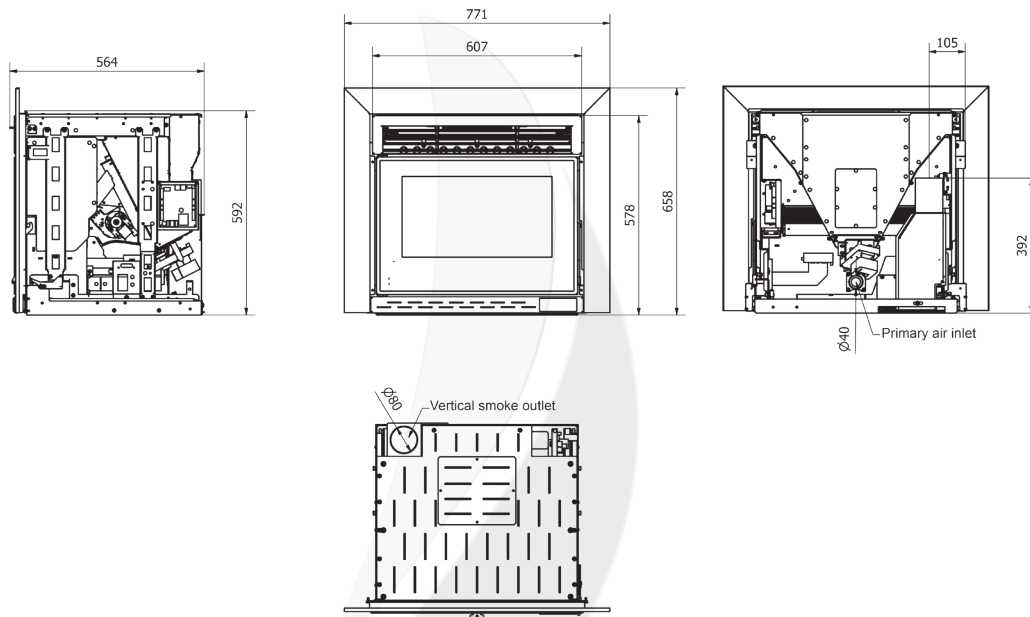

4. FUEL

The FERLUX wood pellet heater has been designed to burn wood pellets that comply with the requirements established in Regulation UNE-EN ISO 17225:2014 regarding Solid biofuels and in Regulation ONORM M 7135.

4.1 WHAT ARE WOOD PELLETS?

Wood pellets are a combustible fuel that are made by pressing natural dry sawdust. The sawdust is easily compacted and the lignin of the material itself acts as a binder, meaning that no glue or other substance is required. This process lends them a shiny appearance, as though they had been varnished, and makes them denser.

They are very small cylinders that measure just a few millimetres in diameter. Their level of humidity is very low and, furthermore, they require little storage space (in order to produce the same amount of heat, around three times less volume of wood pellets is required when compared to firewood).

4.2 PROPERTIES OF WOOD PELLETS

There are various types of wood pellet on the market and they are of varying quality and have different characteristics in their manufacturing processes and types of wood used.

As was stated previously, this heater is designed to operate with DINplus size wood pellets (marking obtained according to Austrian regulation Onorm M 7135) and ENplus (marking obtained according to Regulation UNE-EN ISO 17225-2:2004).

The main requirements of these aforementioned regulations are:

Characteristics of the wood pellet according to DINplus and ENplus regulations			
Requirement	Unit of measurement	DINplus	ENplus
Diameter	mm	$4 \leq D < 10$	D06: 6 ± 1
			D08: 8 ± 1
Length	mm	$\leq 5 \times D$	$3,15 \leq L \leq 40$
Lower calorific value	MJ/kg (b.h)	$Q \geq 18$ (MJ/kg en b.s.)	$16,5 \leq Q \leq 19$
Humidity	% (b.h)	≤ 10	
Ash	% (b.s)	$\leq 0,5$	$\leq 0,7$

A wood pellet that has gained certification under either of these two regulations is the best way to assure the proper functioning of the FERLUX wood pellet heater.

If the wood pellet does not come suitably marked, the appropriate certificate must be requested.

If faced with an unidentified wood pellet, or one which, due to a variety of circumstances, could be deemed to have different characteristics, there are a series of criteria that can be applied to judge whether or not it is suitable for use, for which you should be guided by the following advice:

- DO NOT USE pellets with different dimensions than those stated in the previous table.
- DO NOT USE pellets that show coloured grains that do belong to the wood or which are excessively dark.
- DO NOT USE damp pellets.
- DO NOT USE pellets that contain mixed sawdust, resins, or chemical substances, binders, or additives.

The use of unsuitable fuels causes:

- The build-up of pellets in the brazier.
- Dirtiness in the brazier and smoke evacuation ducting.
- Poor combustion.
- Dirty glass.
- Reduction in the performance of the unit.
- Increased consumption of pellets.
- Normal operation of the heater not to be guaranteed.
- Needing to perform more frequent cleaning and maintenance of the heater.

4.3 STORAGE OF WOOD PELLETS

In order to guarantee problem-free combustion, it is necessary to store the wood pellets in a location that is dry and not too cold. Damp and/or cold wood pellets reduce the power and performance of the fuel and will require the brazier, fireplace, and chimney to be more thoroughly cleaned.

Take special care when storing the wood pellets, as well as moving them, avoiding sawdust collecting and the bags breaking, because if this happens, their level of humidity is prone to increase. If this happens, and the amount of sawdust changes, the calorific properties of the fuel will vary.



USING WOOD PELLETS THAT DO NOT COMPLY WITH THE REGULATIONS PREVIOUSLY STATED COULD DAMAGE THE HEATER AND COMPROMISE ITS PERFORMANCE, GIVING RISE TO THE INVALIDATION OF THE WARRANTY AND TERMINATING THE RESPONSIBILITY OF THE MANUFACTURER FOR THE PRODUCT.

4.4 STOVE SUPPLY

To supply the pellet stove, it will only be necessary to open the tray that is in the upper front part of the appliance using the utensil with cold hands (in case the appliance is in operation).

We empty the pellets on the tray and with the help of the pusher we bring the fuel to the end, making sure that the pellets reach the feed hopper.

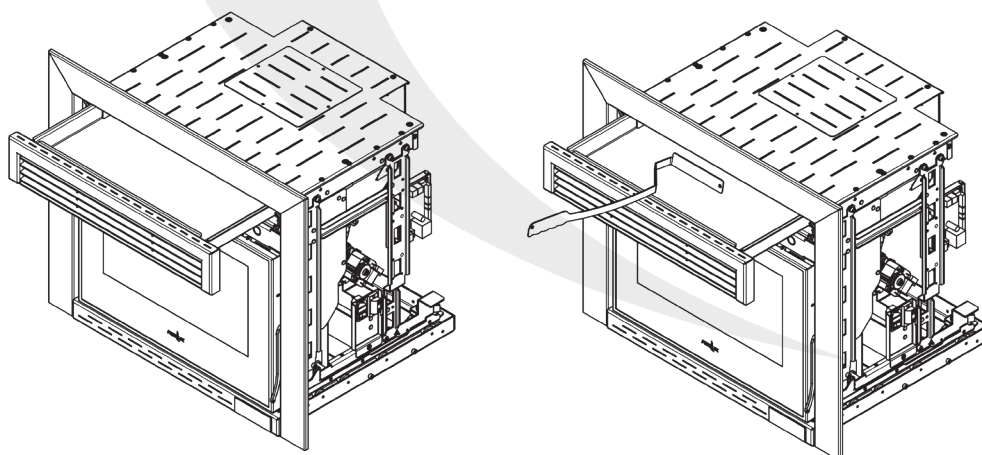

5. INSTRUCTIONS FOR INSTALLATION

The installation of FERLUX wood pellet heaters must be performed solely by qualified personnel who follow the instructions from the manufacturer and in accordance with any and all regulations in force that may be applicable. Failing this, FERLUX is not responsible in the event of any accident.

It is important to choose the location of the heater in such a way that the path to the vertical connection of the smoke outlet is as short as possible.

Both the unit as well as any ducting for smoke are liable to reach high temperatures, meaning that it is essential to follow the instructions from the manufacturer in order to prevent fires and hazardous situations. (See section 5.2 PREVENTION OF DOMESTIC FIRES).

For its correct installation we have to extract the insert from the base and fix it to the surface where it is going to be installed. In this case we have used the optional accessory, height-adjustable table.

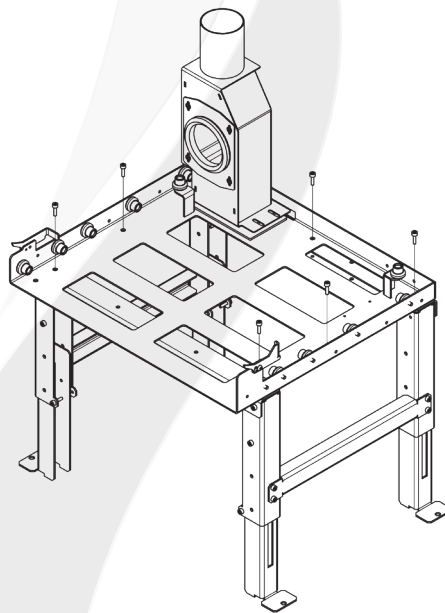

It is also important to take into account the supply of air for combustion, as well as how to maintain suitable atmospheric conditions inside the enclosure. (See section 5.4 VENTILATION AND AIR INTAKE).

5.1 UNPACKING

In order to unpack the product, cut the strap around the packing, making sure not to scratch or damage it. Remove the cardboard and the plastic protector, then remove the lower pallet that the heater comes screwed to.

Open the tank for the wood pellets, where you will find the instruction manual and the power supply cable. Cut the tie that is holding the room temperature sensor to the rear of the unit and attach it in a suitable position so that it can take proper measurements of the exterior temperature. Following this, connect the power supply cable to the rear part of the heater and activate the safety on device to the rear.

5.2 PREVENTION OF DOMESTIC FIRES

- The instructions of the manufacturer must be followed, both for the installation as well as the use of the heater and any safety rules and regulations that apply to it must also be met. Failing this, FERLUX is not responsible in the event of any accident occurring.
- It is recommended that any combustible or flammable items be removed away from the source of heat (at least 1.5 m away), such as wooden beams, furniture, curtains, flammable liquids, etc. A protective layer of insulating and non-flammable material must be positioned in the area of the source of heat where there are claddings that are flammable or sensitive to heat.
- It is necessary to carry out regular cleaning of the heater and of the smoke ducting, since soot and other accumulated combustion residue could end up entering the combustion area.
- In the event that the chimney catches fire, use the appropriate fire extinguishing systems to put out the fire or call the fire service for their intervention.

5.2.1 PROTECTING THE FLOOR

In the case of having a flammable floor (such as parquet, laminate flooring) or heat sensitive floors, it is necessary to place a protection that separates the insertable from the floor. This protection must be made of a fire resistant material such as marble, sheet steel, tiles, etc. This material has to be able to resist without deforming or breaking due to the weight of the insert.

This protection will have a minimum of 2 mm.

5.2.2 MINIMUM SAFETY DISTANCES

The following figures show the minimum safety distances that must always be observed

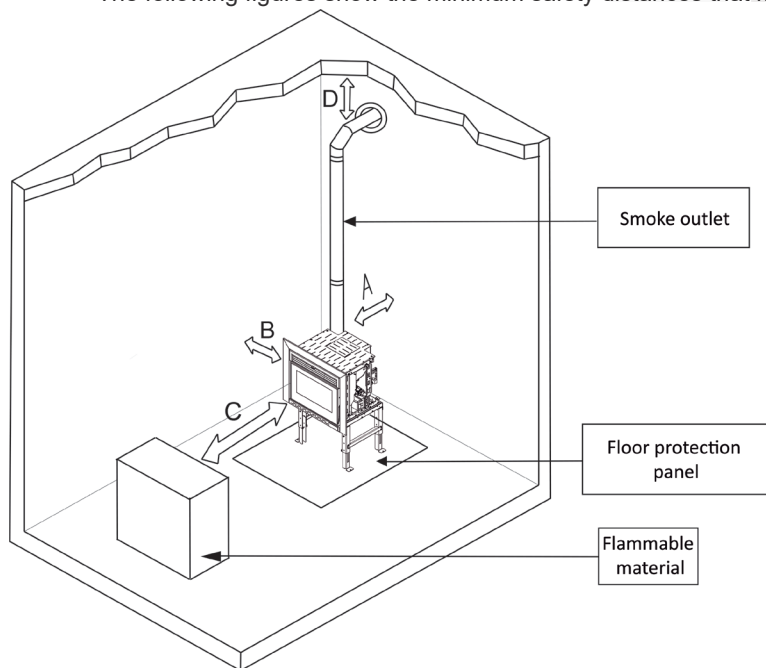

	Safety distances to flammable material	Safety distances to non-flammable material
A	200 mm	100 mm
B	200 mm	100 mm
C	1500 mm	750 mm
D	500 mm	200 mm

5.2.3 MEASUREMENTS TO PIERCE BUILDING ENVELOPES

The ducting for the smoke must pierce the building envelope one or more times depending on where the unit is to be installed.

The size of the holes that will need to be made depends on the diameter of the ducting and of the material to be penetrated. Once a pipe has been passed through, the space must be filled with an insulating material (rock wool, ceramic fibre, etc.)

	Thickness of insulation [mm]	Diameter of holes to be made (mm) for an outlet pipe measuring Ø80 mm
Wall of flammable wood, or with flammable parts	100	280
Wall or ceiling of cement	50	180
Wall or ceiling of bricks	30	140

5.3 SMOKE DUCTING OR CHIMNEY

Smoke ducting or a chimney should be used to vent the gases produced by the heater during combustion to the exterior. The responsibility for the work done to make the smoke ducting lies with the installer, for which reason FERLUX recommends that the installation be carried out by qualified personnel (who are in possession of an installer's licence) to whom enquiries can be made regarding the performance of tests with respect to the smoke ducting, air intake, etc. Furthermore, all the safety regulations laid out by the specific legislation in force in the country where the unit is being installed must be followed.

5.3.1 GENERAL BACKGROUND

The following points must be taken into account during the installation of the smoke ducting:

- **The smoke evacuation system must be unique to each heater** (smoke evacuation systems must never be shared with other units).
- The path of the evacuated smoke must be as short as possible and seek always to be as vertical as possible.
- The internal section of the smoke evacuation ducting system must be uniform and, preferably, circular. In the event that the section is squared or rectangular, the edges must be rounded with a minimum radius of 20 mm, bends must be regular and free of irregularities, ensuring that deviations from the path do not exceed 45° with respect to the axis.
- It is absolutely prohibited to install valves or seals that may obstruct the passage of the smoke.
- Horizontal stretches of the chimney must be avoided, since this causes it to gather dirt and requires the ducting to be cleaned more often. If such a stretch is inevitable, it must be slightly inclined and a 'T' installed at each bend so that it can be cleaned without requiring disassembly of the entire section. The installation must be carried out in such a way that regular cleaning is guaranteed without the need to disassemble the entire smoke ducting assembly.
- The safety regulations and minimum distances must be respected when installing the smoke ducting.

5.3.2 CALCULATING THE EXHAUST SMOKE DUCTING

The following instructions must be taken into account for the path of the chimney:

- Tubes made of AISI Type 316 stainless steel, varnished aluminised steel pipes with a minimum thickness of 1.5 mm, and porcelain pipes with a minimum thickness of 0.5 mm shall be used.
- Flexible pipes are allowed if they meet the specifications set out by law (made of stainless steel with a smooth interior wall), coupling pieces must be at least 50 mm in length.

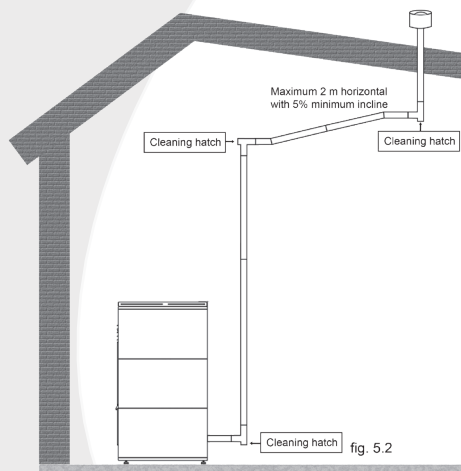

A table is shown below that contains the limitations for the installation:

LIMITATIONS	WITH A PIPE Ø 80 mm	WITH A DOUBLE WALLED PIPE Ø 100 mm
Horizontal stretches with a minimum incline of 5%	2 m	2 m
Minimum length (obligatory in vertical stretches)	2 m	3 m
Maximum length (with two 90° bends)	3 m	8 m

The maximum length for a vertically installed duct with a maximum of two 90° bends and a minimum of horizontal travel (only to pierce the wall, if necessary) has been calculated.

In the event that the installation is different to that previously stated, it will be necessary to calculate the 'equivalent load loss' for the installation..

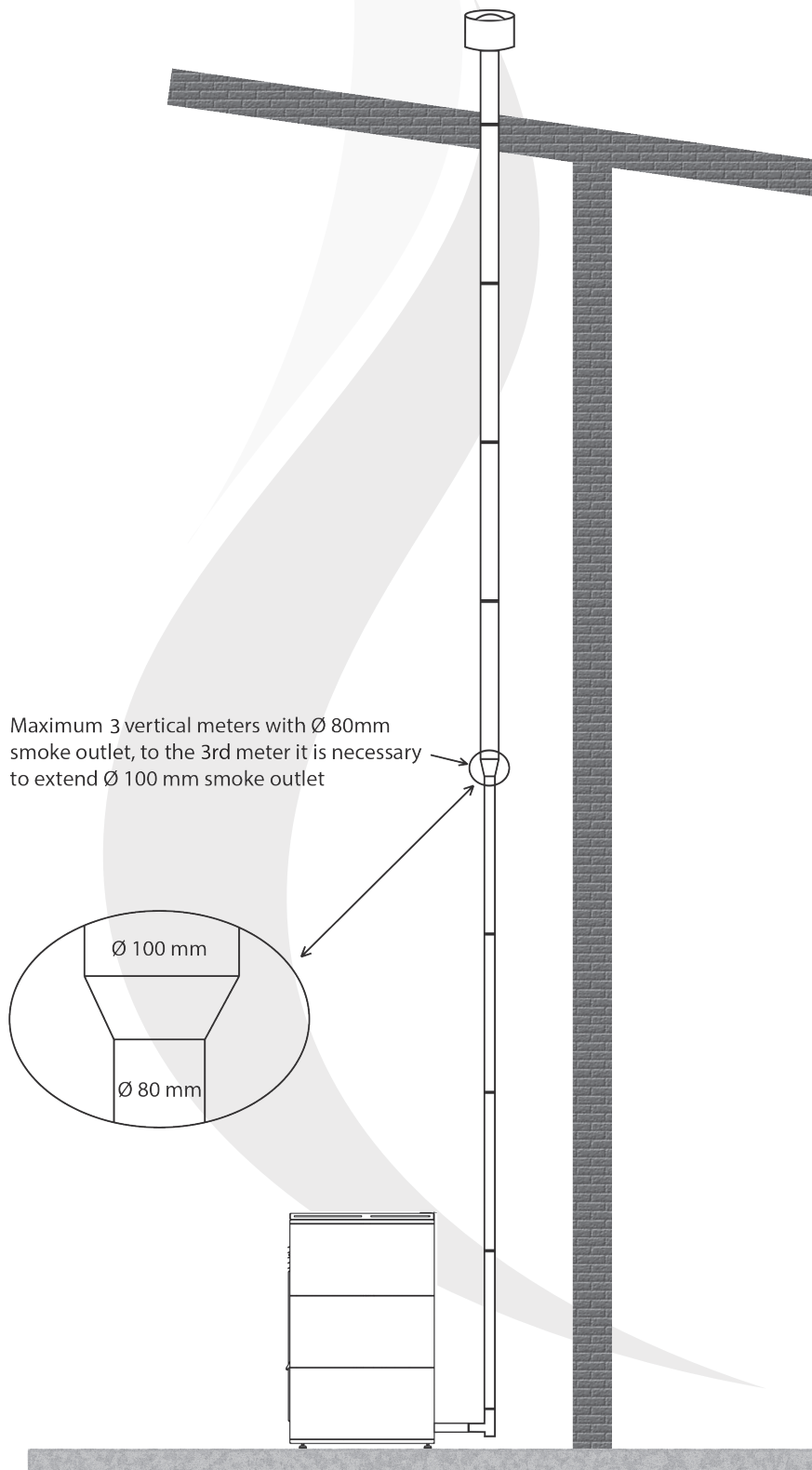

The '**equivalent load loss**' of an installation is the result of the sum of the total metres of the installation added to any additional losses that are shown in the following table:

TYPE OF PATH OR ACCESSORY	LENGTH TO SUBTRACT FROM THE TOTAL ALLOWED
90° bend	1 m
Horizontal stretch 45° bend	1 m
`T' accessory	1 m
Diagonal stretch	0,5 m
45 ° bend	0,5 m

The sum of these losses must be equal to or less than the maximum length allowed shown in the table of limitations. If this is not met, the diameter of the smoke ducting to be installed must be increased:

LOSS OF EQUIVALENT LOAD ≤ MAXIMUM PERMITTED LENGTH

5.3.3 INSTALLATION IN TRADITIONAL-TYPE CHIMNEYS (see fig. 5.3 and 5.4)

If you wish to make use of an existing chimney structure, it is necessary to carry out some tests to check its seal. If the existing chimney is not sealed, the situation could arise where there is a positive depression with respect to the atmosphere, meaning that there could be an ingress leak into living spaces. If the seal is not fully tight, it is advisable to put new pipework in.

If the cross-section of the chimney is excessively large, pipework with a maximum diameter of Ø 150 mm could be considered, with it being advisable to also install insulation around this.

5.3.4 EXTERIOR STRETCH OF THE CHIMNEY (see fig. 5.5)

If an exterior stretch is anticipated for the chimney, it must meet the following requirements:

- The part of the installation that penetrates to the exterior must be made with insulated and double-walled pipes made of stainless steel and attached to the building.
- This ducting must have an inspection hatch for regular maintenance tasks.
- The chimney must rise to the gable of the house, in line with the requirements stated in section 5.3.

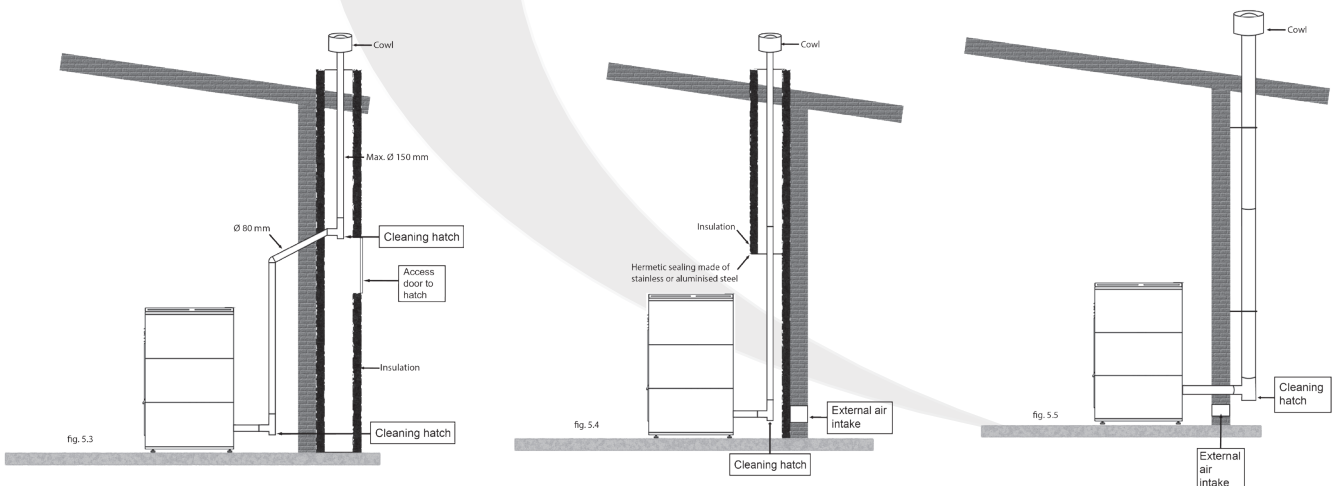

5.3.5 CAPPING OF SMOKE OUTLETS

The smoke outlet must always terminate on a vertical and the upper part of the section, which shall be termed the cap, must comply with the following requirements:

- It must have a useful internal cross-section equivalent to the evacuation pipes.
- The useful cross-section of the outlet must be at least double that of the evacuation pipes.
- The cap must prevent rain, snow, or foreign bodies from entering the chimney, otherwise it could cause **Er02** or **Er41**.
- Furthermore, the cap must be resistant to winds and rise above the gable of the house in order to ensure dispersion and dilution of the products of the combustion. Failure to install according to these guidelines may cause **Er02** or **Er41**.
- It is absolutely forbidden to install cowls or deflectors for a horizontal outlet, above all those used for gas boilers, since they could cause problems with the combustion, installing these could result in **Er02** or **Er41**.

For errors see Chapter 9 of this user and installation manual.



It is absolutely forbidden to cover the chimney with anti-bird nets or meshes or any similar product.

5.4 VENTILATION AND AIR INTAKE

- In the room where the stove is installed, we must make sure that we have air at all times, necessary to guarantee good combustion, in addition to optimal habitability conditions within the enclosure.
- The outside air inlet, whenever possible, must be in communication with the room where the stove is installed. We must make sure that the outside air intake cannot be obstructed.
- If we do not have sufficient natural ventilation in the room where the stove is to be installed, is essential to make an opening, which guarantees us the necessary air from outside (at least it will have a 100 cm² section).
- The air intake can also be obtained from an adjacent room, as long as the said flow can easily reach through permanent openings, which cannot be closed and which communicate with the outside.
- Moreover, the room cannot be used as a garage, storage of material or activities with fire risk.
- Two appliances, a fireplace and a stove, ... should not be used in the same room since the draft of one could interfere with the other's
- Collective ventilation ducts are prohibited.
- • The air intake must be positioned respecting the following distances:
 - ▶ 1.5 m away from the smoke outlet.
 - ▶ 0.3 m above windows, doors, cameras, etc.
 - ▶ 1.5 m horizontally away from windows, doors, cameras, etc.
 - ▶ 1.5 m below windows, doors, cameras, etc.
- The air intake for combustion cannot be connected to any air installation, nor is it recommended air intake directly from the intake made in the wall.

In the case where there is no other way than to connect the primary air intake directly to the intake practiced in the wall it should be of a larger diameter, in order to avoid all the problems caused due to the lack of primary air intake. The air intake made in the wall will not have any type of mesh mosquito net or similar as this reduces the primary air intake to the appliance with the consequences that this implies in the ignition and operation of the same (**Er41**, see Chapter 9 of this manual)

The extensions that must be made are the following:

- When the primary air inlet into the device is \varnothing 40 mm, we must extend it to \varnothing 90 mm
- When the primary air inlet into the device is \varnothing 60 mm, we must extend it to \varnothing 110 mm

IN CASE OF CHANNELING, AVOID ANY KIND OF BEND.

IT IS TOTALLY FORBIDDEN THE INSTALLATION OF COAXIAL TUBE ON ANY FERLUX APPLAIENCES.

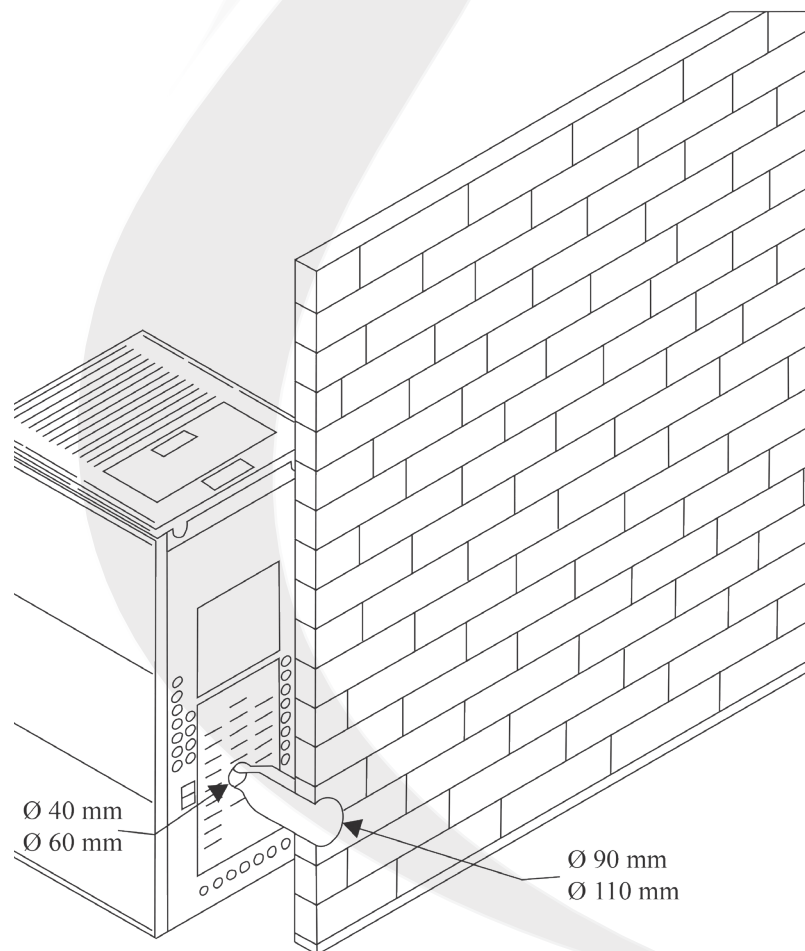



For the proper functioning of the equipment, it is essential that the installation provides a sufficient air intake for combustion and oxygen regeneration. For this we must place openings that communicate with the exterior of the cladding, there must be circulation for combustion even with the doors and windows of the room closed.

The air intake must be positioned so that it cannot be covered or obstructed. In addition to being protected by a grid. This installation must be upper and lower, and the grilles can be optionally on the front or sides of the cladding as indicated in the drawing.



It is mandatory that the room temperature probe comes out of the device's coating as indicated in the drawing below, so that the temperature set by the probe is correct, avoiding a malfunction due to a wrong reading of the room temperature.

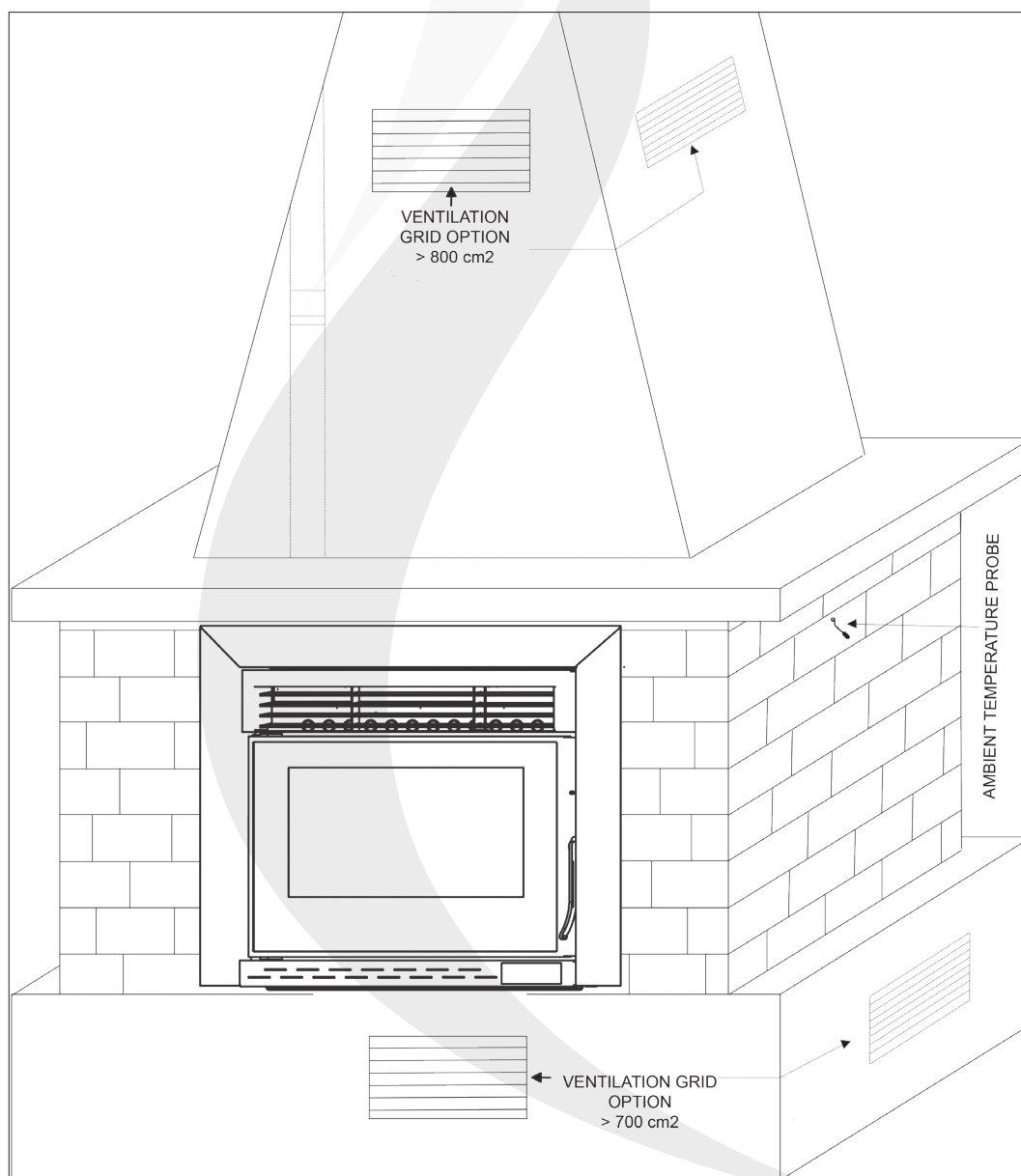

5.5 ELECTRICAL CONNECTION

It is necessary to have a mains power outlet of 230 V with a ground connection for the installation of the heater. The power outlet must be capable of conveying at least 450 W of power for the lighting of the heater and must have its own breaker.

The heater is powered by means of a power cable that must be connected to the 230 V outlet. Make sure that the heater's general switch is set to 0 and then connect the power supply cable, first behind the heater and then to the electrical outlet.

By law, the installation must have a ground connection and breaker switch. Make sure that the electrical power supply cable is laid in its final position and will not come into contact with any hot parts.

! The power outlet must be single phase with a live, neutral, and ground connection.

i If the mains voltage is not sinusoidal (as with, for example, generators), the heater could show an error. The user have to install the appropriate device to achieve a pure sine wave with a voltage between 220-230V

6. INSTRUCTIONS WHEN USING THE CONTROL PANEL

Below, an image is shown of the display that is made up of four flashing lights and two displays with four digits on each one, also including LEDs that provide information, as shown below:









KEY	FUNCTION	
	CLICK	LONG PRESS
P1	Information/Exit Menu	On/ Off/ Reset alarms
P2	Adjust thermostat (+)/ Increase	
P3	Adjust combustion power	First screw fill
P4	Adjust thermostat (-)/ Decrease	

The upper display only shows one thing, whereas the lower screen displays varying information depending on the situation. We have classified the displays at each time so that they can be seen below. Depending on the menu item that is open, the display could show the following:

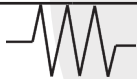
- **Display D1:** Time, operational status, errors, Menu, Submenu, and values of parameters.
- **Display D2:** Power, codes of parameters (this is only shown when the heater is operating).
- **Display D3:** Room temperature.



INTERPRETING THE LEDS WHEN THEY LIGHT UP			
L1		LED lit: the room fan is switched on	
L2		LED lit: the screw in ON	
L3		LED lit: the ignition coil is switched on	
L4		LED lit: ambient temperature reached	
L5		G	LED lit: daily scheduling is activated
L6		S	LED lit: weekly scheduling is activated
L7		W	LED lit: weekend scheduling is activated

If the previously indicated parameters cannot be seen on the display (such as the display does not show the time and temperature in the usual way) or the keys do not give access to the functions mentioned in this manual (such as for example, you cannot use the keys  (P2) or  (P4)), it could be that during the manipulation of the display the setting.



THE DISPLAY CONFIGURATION IS CHANGED BY PRESSING THE SAME TIME IN THE WAY LONG (for more than 30 seconds)  (P1) AND  (P3).

IT WILL BE CORRECTLY CONFIGURED WHEN “110” APPEARS ON THE TOP DISPLAY, AS SHOWN IN THE IMAGE BELOW.

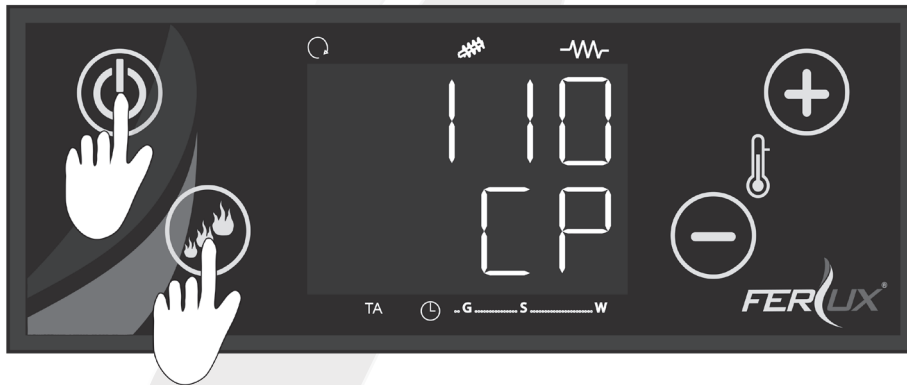

6.1 MENU LEVEL 1

The options that the user can access from the 'Main Screen' (the screen normally displayed when no buttons have been pressed) are known as 'MENU LEVEL 1'.

6.1.1 INFORMATION

Each time you click the button, you can see the on the lower display an abbreviation for the name of a parameter, and on the upper screen, you can see its value.

The parameters displayed in the order that they appear are:

tF: temperature of the smoke (°C)

tA: room temperature (°C)

FL: primary air flow speed

UF: revolutions of the fume extraction turbine / voltage of the fume extraction turbine

Co: On time of the screw

St2: time remaining until routine maintenance (h)

FC: firmware code and revision

514: manufacturer item codeX

To return to the main screen, refrain from pressing the button  (P1) or five seconds.

6.1.2 REGULATION THE POWER

This heater has five power levels at which it can operate, where 1 is the lowest power and 5 is the highest. These levels can be selected by the user by clicking the button  (P3).

As well as being able to choose between the five power levels, the heater also gives us the choice of choosing an automatic operation mode, 'A'. In this mode, the heater selects the best power level for the moment with respect to the preset temperature, modulating itself and thus achieving a more constant temperature, faster heating, and lower fuel consumption.

Push the button  (P3) and the lower display D2 will begin to flash. With each click of this button, the power level is increased and finally automatic mode will appear.

In order to set the value desired, refrain from pressing the button  (P3), it will then stop flashing and the power value desired shall be selected.







6.1.3 REGULATION THE ROOM TEMPERATURE

Each user has the option to choose the desired room temperature.

When a preset temperature is chosen, the heater will compare it with the temperature detected by the room temperature sensor.

As long as the preset temperature is above the temperature measured by the room temperature sensor, the heater will run at the power level selected. When the room temperature approaches the preset temperature, the heater changes to modulation 'mod'.

If, whilst in modulation mode, the temperature detected by the room temperature sensor should rise by more than 3 °C, the heater will turn itself off by putting itself in 'standby' mode. The heater will turn itself back on when the room temperature is beloww the desired room temperature.



To modify the preset temperature, click on the  (P2) or  (P4) button. On the lower display (D3) the preset temperature that was already chosen can be seen flashing, which can be increased or decreased by clicking on the  (P2) or  (P4) buttons, respectively. After five seconds without any button being pressed, the new value will be saved and the display will return to the main screen.



6.1.4 RESET ERRORS, TURNING THE HEATER ON AND OFF

If you long press the  (P1) button, the heater's state will change from the one it was in before the button was pressed.

The following circumstances could arise:

STATE BEFORE LONG PRESS 	STATE AFTER LONG PRESS 
STOP (no alarm) (The display shows the time and the room temperature)	ON (The display shows Chec, ON1, ON2,...)
STOP (with alarm) (The display shows Er02 [example] and ALT intermittently)	STOP (no alarm) (The display shows the time and the room temperature)
ON, NORMAL, MODULATION OR STANDBY	OFF
OFF	`rec´(Turn on recovery)
"rec" (Turn on recovery)	OFF

6.1.5 LOADING THE PELLET SCREW



This function allows you to fill the screw for the first time that the heater is going to be started up and also when, for whatever reason, the fuel tank has been completely emptied.

This is done by pressing the  (P3) button, with the loading screw being activated continuously. Whilst the lower display shows `LoAd`, the upper display will show for how long it has been operating. Stop loading when the pellets fall uninterrptedly into the brazier, which can be achieved by pressing any button. For safety reasons, loading is automatically interrupted after 300 seconds.



AFTER CARRYING OUT THIS OPERATION, BEFORE PROCEEDING TO TURN THE HEATER ON, IT IS NECESSARY TO EMPTY THE BURNER AND REPLACE IT CORRECTLY. IF IT IS NOT CORRECTLY REPLACED, IT COULD CAUSE DIFFICULTY WHEN TURNING THE UNIT ON

6.2 MENU LEVEL 2

The functions that can be accessed in a submenu that is reached by long pressing  (P3) and  (P4) are known as 'MENU LEVEL 2'.

The functions of this submenu are as follows:

rAir: Regulation of the fan.







Cron: Timer to programme the heater to turn on and off.

orol: Clock.

tEIE: Remote control.

rCLr: Cleaning reset.

TPAr: Technical menu.







When you push the  (P3) and  (P4) buttons at the same time, the first function of 'menu level 2' will appear on the upper display (D1). Using the  (P2) or  (P4) buttons, the user can move around and select the different functions. Once the desired function has been chosen, click on the  (P3) button. If you wish to return to the main screen, press the  (P1) button.

After around 40 seconds without any button being pressed, the display will return to the main screen.

6.2.1 [rAir] REGULATION OF THE FAN

This menu allows you adjust the power of the heating fan.

There are seven power levels above the default power level setting and seven levels below the default power level setting.

To access the function 'rAir' long press the  (P3) and  (P4) buttons until 'rAir', immediately after this, press the  (P3) button and figure '0'. Press the  (P3) button again and the '0' will flash. With the  (P2) or  (P4) buttons, select the desired power for the fan, either faster or slower than the default power level setting.



6.2.2 [Cron] PROGRAMMING SCHEDULES



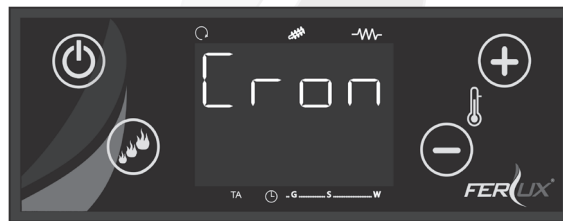

This function allows on/off times to be set for the heater.

This function has two sections, one to choose the scheduling mode that you wish to activate (ModE), and the other for programming the schedules for each one of the modes (ProG).

In order to access this function, long press the 🔥 (P3) and ⏪ (P4) buttons. `rAir` will appear on the upper display (D1), then press the ⏩ (P2) button and `Cron` will appear, meaning that this function has now been accessed. Now, immediately press the 🔥 (P3) button, enter into the programming mode that was mentioned previously (ModE) or (ProG), which can be navigated with the ⏩ (P2) or ⏪ (P4) button and then selected with the 🔥 (P3) button.



(ModE): This allows the “Cron” function to be deactivated or for a choice between three options:

Mode	LED
Gior: Daily Scheduling	 <input checked="" type="radio"/> G <input type="radio"/> S <input type="radio"/> W
SEtt: Weekly scheduling	 <input type="radio"/> G <input checked="" type="radio"/> S <input type="radio"/> W
FiSE: Weekend scheduling	 <input type="radio"/> G <input type="radio"/> S <input checked="" type="radio"/> W
OFF: The heater does not have any schedule activated	 <input type="radio"/> G <input type="radio"/> S <input type="radio"/> W

When entering (ModE), press the 🔥 (P3) button and on the upper display (D1), the option that is currently active will be shown (which could be: Gior, SEtt, FiSE or OFF). In order to change which option is active, press the 🔥 (P3) button again to make the option begin to flash, use the ⏩ (P2) or ⏪ (P4) buttons to select the desired option, press the 🔥 (P3) button again, and the option currently flashing will be selected. Press the ⏪ (P1) button repeatedly to return to the main screen.



If you accidentally press the ⏪ (P1) button without having confirmed the option or if no button is pressed for a certain time, the display will return to the main screen and the option that was previously selected will remain active.

(ProG): This function allows scheduling of the three modes offered by the electronic control board, with up to three time slots that can be scheduled (three on as well as three off) each day:

Daily (Gior): each day of the week is scheduled independently.



Weekly (SEtt): a single schedule is created that is applied to every day of the week.

Weekend (FiSE): in this case, two schedules are created, one for Monday to Friday and another for the weekend (the latter coming into force on Saturday and Sunday).

SETTING	DISPLAY
(Gior): daily scheduling	Mo: Monday tu: Tuesday UE: Wednesday tH: Thursday Fr: Friday SA: Saturday Su: Sunday
(SEtt): weekly scheduling	MS: from Monday to Sunday
(FiSE): weekend scheduling	MF: from Monday to Friday SS: Saturday and Sunday
Time on (ON)	
Time of (OFF)	

In order to configure each schedule, you have to set the ON time and the OFF time.

ON MENU SCHEDULING

- Once you have entered the (ProG) menu, use the  (P2) or  (P4) buttons to choose one of the three modes that you wish to schedule and confirm the selection by pressing the  (P3) button.

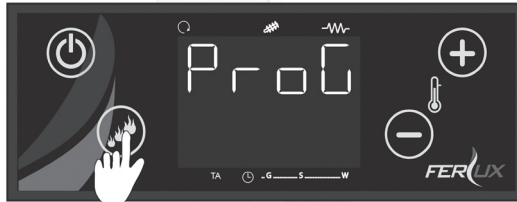

- Once you have selected the mode, it will appear on the display as shown below:

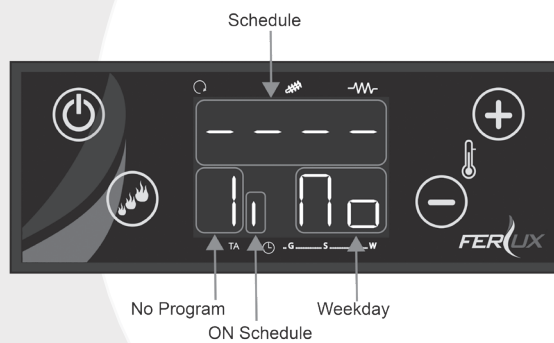

- After this, long press the  (P1) button and on the upper screen (D1), the hours and minutes of the ON state will appear as shown below:



- To adjust the on time, click on the (P3) button and the hours will begin to flash, with the (P3) button, change from hours to minutes and viceversa. To adjust the hour and/or minute values, use the (P2) or (P4) buttons.
- Once you have set the schedule, push the (P3) button again to save the desired value. The screen will finally be left as shown below.



OFF MENU SCHEDULING

To schedule the unit to turn off, you should proceed in the same manner as previously instructed. Once at stage two of the previous section and after having chosen the scheduling mode desired, you must press the (P2) button. After this, the display will show the following:

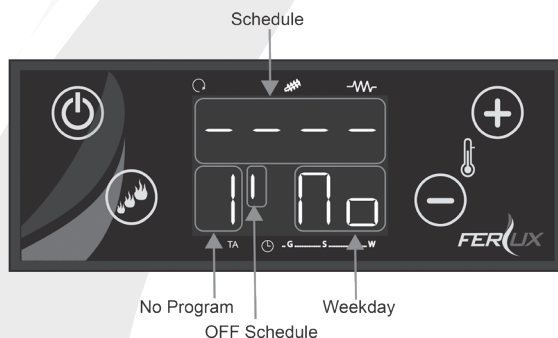

After this, repeat the previous procedure until point three.

For the days of the week, do the same, repeating the previous procedure.

If the mode selected was Weekly or Weekend, the method of proceeding is the same.

The minutes can be changed with intervals of one quarter of an hour (such as, for example: 17:00, 17:15, 17:30, 17:45). There is a special adjustment for times between 23:45 and 23:59, for which it is possible to make minute by minute adjustments.

EXAMPLE OF SCHEDULING

In order to keep the heater lit for two days, that is, from Monday to Tuesday, set the scheduling time slot for Monday to OFF at 23:59 and for the scheduling time slot for the following week, in this case, Tuesday, to ON at 00:00.

SCHEDULING MONDAY			
ON	17:45	OFF	23:59
SCHEDULING TUESDAY			
ON	00:00	OFF	12:30

6.2.3 [oroL] CLOCK

This function allows you to set the date and the time. This setting is required in order to design schedules for turning the heater on and off.

Once you see the following menu displayed on the screen, proceed as follows:



Press the (P3) button and the screen will immediately show the following:



Press the (P3) button again and the hours will begin to flash. If you continue to press this button, the minutes or days of the week can be adjusted. When the hours, minutes, or days of the week are flashing, use the (P2) or (P4) buttons to adjust these values.

To exit this function, press (P1) button or wait a few seconds. If you push this button before selecting and confirming, the information will not be saved.

6.2.4 [tELE] REMOTE CONTROL





This function is used to activate and deactivate the remote-control functionality.

This menu is disabled by factory default (OFF). In order to enable remote control functionality, it is necessary to activate this function (ON).

The procedure is as follows:

1. Go to the [tELE] function and press the (P3) button, as shown below



- After this, the following screen will appear, press the  (P3) button and use the  (P2) or  (P4) to select the ON option to activate the remote control. To confirm, press the  (P3) button again.

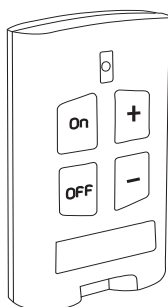
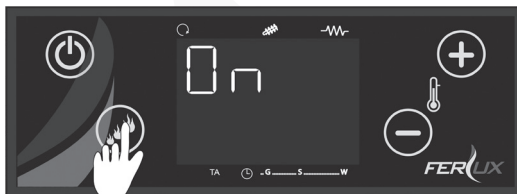

The control unit recognizes the remote control signal (remote control) by means of a code, which can be modified.

For a correct transmission between remote control and control card the transmission code has to be the same in both devices.

If you have other devices in the home that may cause interference in the transmission between the remote control and the control card of the stove, you must change the transmission code following the instructions given below.

ABOUT REMOTE CONTROL

It is possible to choose 6 combinations for the remote control signal at different frequencies.

- We start by pressing two buttons on the remote control for more than 10 seconds: we keep pressing these two buttons that can be combinations (on +), (on -), (on off), (+ -), (+ off) o (off -).
- Then the upper red LED starts flashing rapidly (100 ms on and 100 ms off).
- After 10 seconds, the led remains on.
- To confirm the change, release the buttons after 5 seconds. If the buttons are not released within 5 seconds the LED goes off and the frequency change is not made.
- Then turn off the power to the appliance, and reconnect it after about 10 seconds. When you reconnect the power to the appliance, keep any button on the remote control pressed until you hear a “beep”

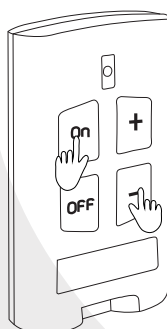

6.2.5 [rCLr] TECHNICAL MENU 1

This function corresponds to a technical menu that can only be accessed by the Service Technician.

6.2.6 [tPAr] TECHNICAL MENU 2

As with the previous one, this function corresponds to a technical menu and is for the exclusive use of the Technical Support Service.

7. USE AND FUNCTIONALITY OF THE HEATER

7.1 ADVICE AND CAUTIONS

- Before turning the device on, make sure that there is no flammable material inside or near the heater that could enter the combustion process.
- Use fuel that is recommended by the manufacturer.
- Do not use the unit as an incinerator or for any other use apart from the use for which it has been designed.
- The external surfaces of the heater, especially the glass, reach high temperatures when touched, meaning that it is necessary to take the proper precautions to avoid burns.
- Consult this instruction manual if you are uncertain about any point. Do not manipulate the display until you are sure which procedure you must follow.
- Pay special attention to the alarms and messages that are shown on the display. It is even recommended to make a note of them, which will make the work of the Technical Support Service easier in the event that they are involved.
- Before turning on the heater, make sure that: nothing is obstructing the air inlet pipe, the burner is properly positioned and clean, the ashtray is in place, and the front door that provides access to the combustion chamber is properly closed. The door must only be opened when the heater is stopped and cold.
- It is absolutely forbidden to remove the protective grille that is located in the tank.
- Do not touch the heater with wet hands because it is an electrical device.



During operation, the unit experiences considerable expansion in the process of heating and cooling, which means that it is absolutely normal to hear clicking sounds made by the steel frame. Under no circumstances can this be considered to be a defect of the unit.

7.2 FIRST LIGHTING

- I. Make sure that the heater is properly connected to the mains power supply.
- II. Following this, turn on the general switch on the heater, which is located on the rear part of the heater next to the connection for the cold air intake.
- III. After this, the time will appear on the upper display (D1) and the temperature on the lower display (D3).



- IV. At this time, the error Er11 could also appear on the display, which means that the time and date are not updated, which can occur after a long period of not being connected to a mains power supply. See chapter 9 'ERRORS AND SOLUTIONS' in order to find out how to continue, because if there is an error on the screen, the unit cannot be properly started up.
- V. To turn on the heater, hold the (P1) button pressed down until a beep is heard. At this point, the display will show the following.

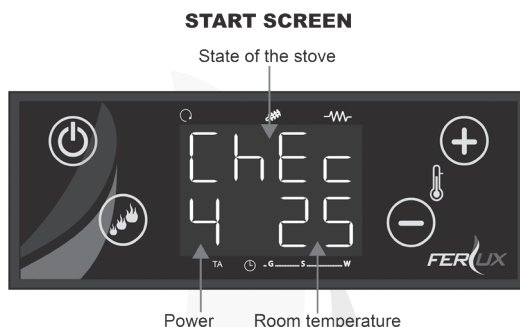

At this time, the electronic control board will perform a “ChEc” test on the heater, during which it will carry out a range of verifications. If the control board detects any anomaly, it will not start up and will instead give the corresponding error message. If everything is correct, the heater will begin the process of starting up.

During the operation of the first starting up, ‘smoke’ may be seen to exit the heater inside the room where it is installed, this is due to the solvents and varnishes in the paint drying out and will disappear after a few hours. It is recommended that you keep the room well ventilated during this time.

7.3. STATES OF FUNCTIONALITY

7.3.1 LIGHTING

When the heater changes from being off to standby or operation, this stage is known as the lighting stage.

This stage can be subdivided into the following steps: Checking, Pre-heating, Pre-loading, Fixed lighting, Variable lighting, and Stabilisation. During these stages, the user will be able to see the following messages on the upper display:

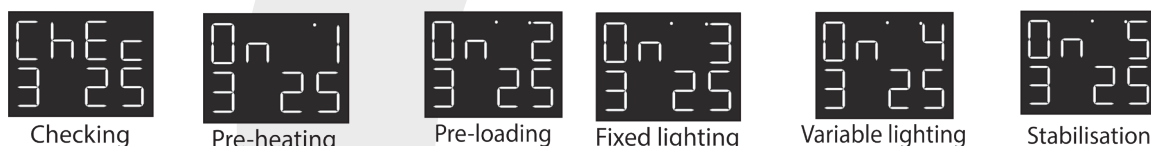

7.3.2 NORMAL HEATER OPERATION

The heater enters this stage when it has finished the entire process of lighting.

The time will appear on the upper display, and the operating power and room temperature on the lower display. The upper LEDs will also indicate the elements that are operating, such as the room fan, the screw, and the ignition coil.



7.3.3 HEATER OFF

The heater can be found in this state when the general switch is turned on or after extinguishing. The time will be displayed on the upper display with the room temperature on the lower display.



7.3.4 MODULATION ("MOD")

This phase occurs during normal operation when the desired room temperature set by the user has been reached. When the heater is in modulation mode, the word 'Mod' will appear flashing on the upper display, as shown below: The heater detects that the heat generated cannot be fully exchanged, meaning that modulation mode is initiated to :



ensure maximum exchange, maximum performance, and fuel saving.

7.3.5 STANDBY

If the ambient temperature in the room continues to rise during the modulation state, the heater will enter standby stage. Initially, it turns off and remains in this state. It will automatically turn back on when the room temperature falls one degree below the desired room temperature. This ensures optimum comfort and lower fuel consumption.

7.3.6 OFF

This phase can be initiated for a variety of reasons, as shown below:

- Pressing the ON/OFF button, which forces the unit to turn off.
- The heater enters the standby stage.
- An error message appears.
- The heater is in the ignition recovery stage.

During the switch-off phase, the upper display will show the word 'OFF', as been below:



7.3.7 RECOVERY OF THE IGNITION ('REC')

This stage causes the heater to turn itself off whilst the word 'rEc' will appear in flashing letters on the upper display. When the turning-off process concludes, the heater will automatically turn itself on.

The heater can enter this stage due to the following reasons:

- If during the process of turning the heater off ('OFF'), the user pushes the ON/OFF button again to turn it back on.
- If the heater is in a normal operation stage and a power cut occurs in the mains power supply and if the heater is still hot when the mains power supply comes back online.



8. MAINTENANCE AND CLEANING

It is necessary to carry out certain maintenance tasks in order to keep the heater functioning properly. The frequency of these maintenance tasks will depend largely on the hours of operation and the quality of the fuel that is being burned. Some of these maintenance tasks must be carried out daily and others can be carried out on a seasonal basis.

A table of the tasks that require carrying out is shown below:

CHORES	FREQUENCY						
	DAILY	WEEKLY	MONTHLY	QUARTERLY	ANNUAL	USER	TECHNICIAN
Cleaning the brazier, cleaning the holes in the brazier, and removing ashes	✓					✓	
Removal of ashes from the burner	✓					✓	
Use of the scrapers	✓					✓	
Empty ashtray and vacuum the grate and housing		✓				✓	
Clean the inspection "T"			✓			✓	
Internal cleaning of the combustion chamber (depending on fuel quality)				✓	✓	✓	✓
Door cord decompression			✓			✓	✓
Extraordinary cleaning					✓		✓



AN ASH VACUUM CLEANER IS REQUIRED TO CLEAN THE HEATER



GENERALLY, IT IS NECESSARY TO CLEAN THE BRAZIER AFTER 10-12 HOURS OF CONTINUOUS OPERATION, ALTHOUGH A HIGHER FREQUENCY COULD BE REQUIRED IF INFERIOR PELLETS ARE USED



BEFORE TURNING ON THE HEATER, MAKE SURE THAT THE BRAZIER IS PROPERLY SEATED IN POSITION



TO CARRY OUT THE CLEANING AND MAINTENANCE TASKS, IT IS NECESSARY THAT THE HEATER BE DISCONNECTED FROM THE MAINS POWER SUPPLY, FULLY TURNED OFF, AND COLD



LACK OF CLEANING CAN AFFECT THE SAFETY AND CORRECT OPERATION OF THE HEATER



AFTER A LONG PERIOD OF DISUSE, EMPTY THE PELLET TANK OF ANY REMAINING PELLETS SINCE THESE COULD HAVE ABSORBED MOISTURE FROM THE AIR, CHANGING THEIR ORIGINAL PROPERTIES AND MAKING THEM UNSUITABLE FOR USE

8.1 CLEANING THE BRAZIER AND BRAZIER HOLDER

According to the quality of the fuel, crusts may form that hinder the correct operation of the heater, meaning that they should be removed from the brazier.

Lift the brazier up and clean these crusts and remove the ash, always taking care to unblock any holes that may have become blocked.

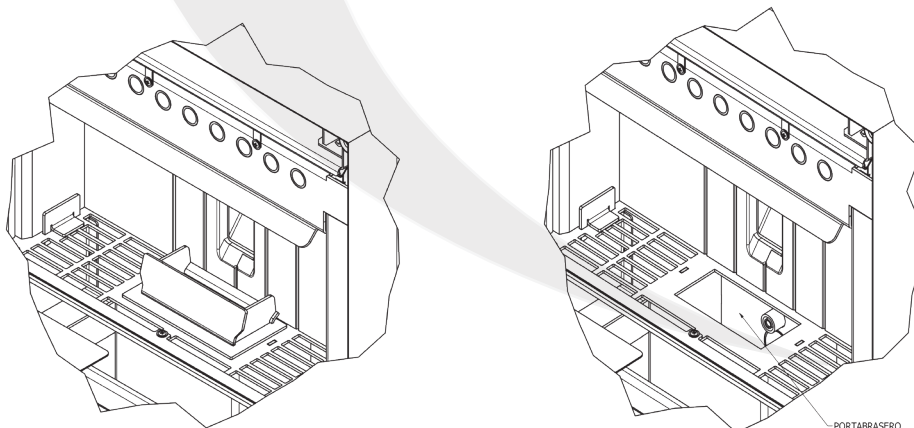

With an ash vacuum cleaner, remove the ash accumulated inside the chamber, and inside the brazier holder

8.2 CLEANING THE ASH DRAWER

The ash collection drawer surrounds the brazier holder, which must be regularly emptied to prevent it overflowing with ashes.

The ashes must be placed in a metal container with a sealed lid until the ashes are wholly and completely extinguished. The closed contained must be placed on a non-flammable base or the ground and well away from flammable materials. Once the ash drawer has been emptied, put it back in its position.

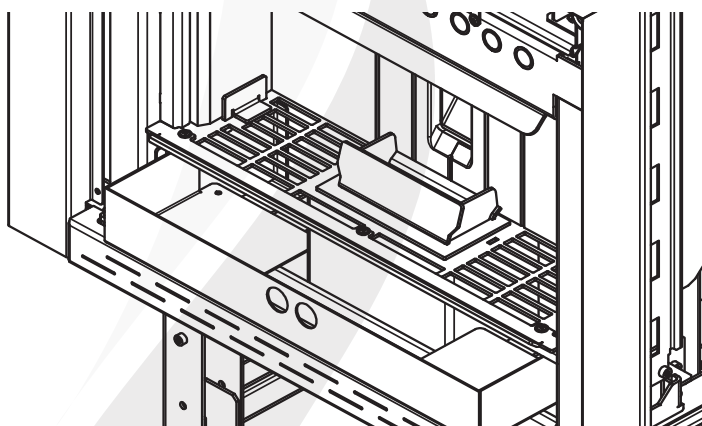

8.3 CLEANING THE INTERIOR OF THE COMBUSTION CHAMBER

Follow the steps as indicated in the following images, take special care with the insulator that you will find behind the front vermiculite, this is an insulating material, which should be replaced if it is not in optimal condition.

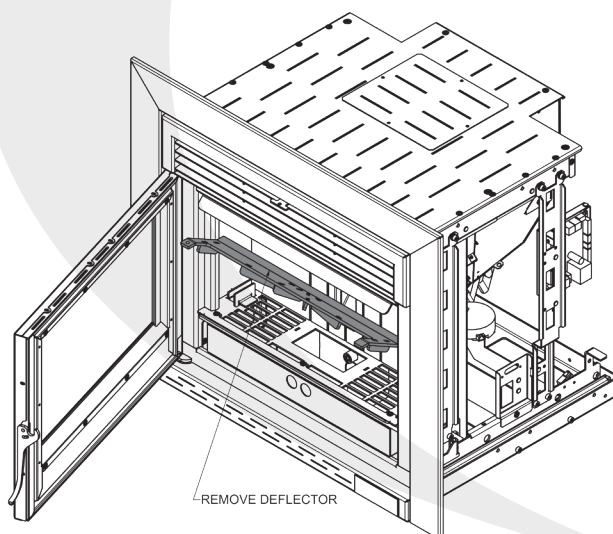

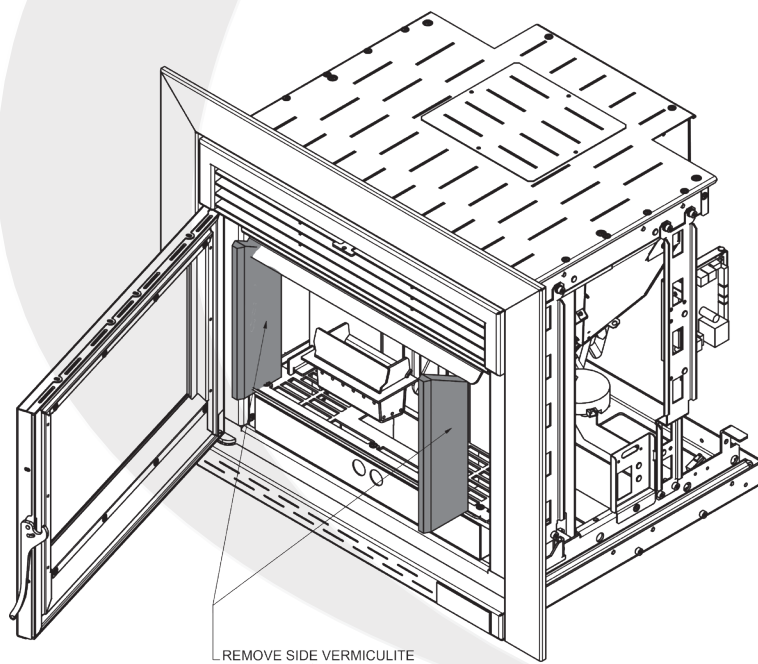
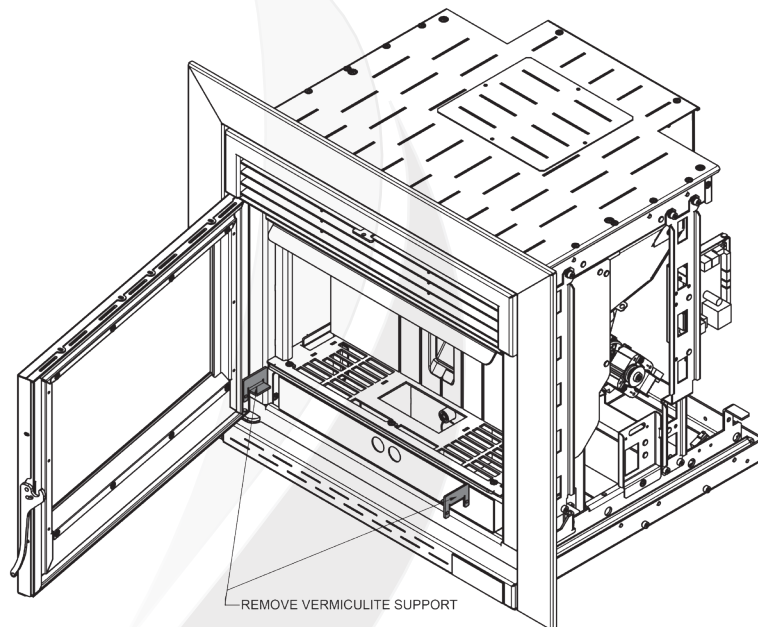

8.4 CLEANING THE GLASS

Regularly clean the glass door of the heater with a degreasing product (not one that is corrosive or abrasive). If the glass is still warm, leave the door open before cleaning for as long as the heater requires to cool down. Do not use materials that could damage or scratch the glass.

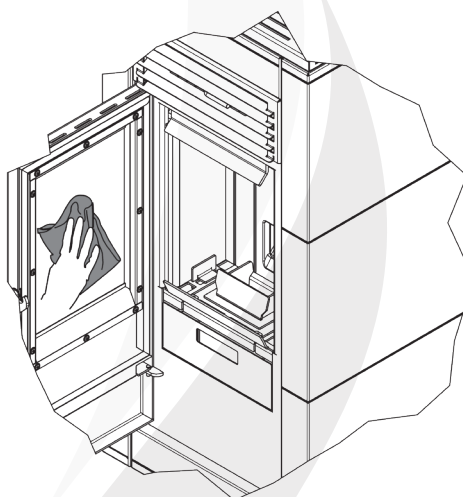

8.5 UNPRESS THE DOOR CLOSURE CORD

It is advisable that the cord be stretched monthly in the months of use of the device to avoid problems when not being properly flattened due to use, causing problems of not adjusting the door correctly when closing, causing problems such as lack of flow for startup or during operation.

By running your finger and releasing the cord a bit both from the top and the bottom we will avoid these possible incidents caused by the use of the device.

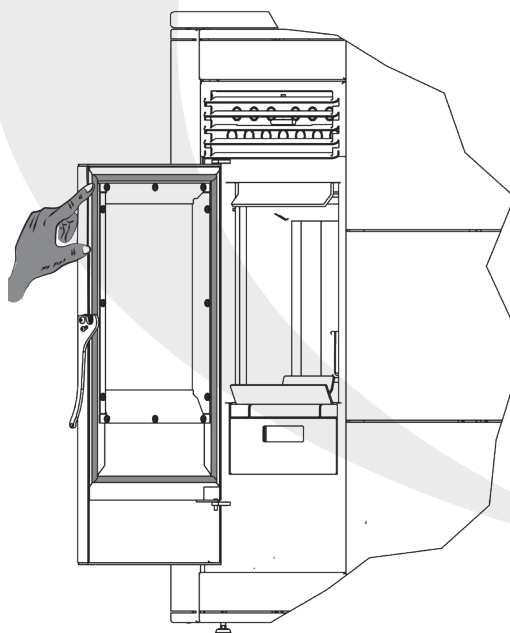



IF THE GLASS OF THE DOOR IS ACCIDENTALLY BROKEN DURING CLEANING, DO NOT LIGHT THE HEATER AND CONTACT THE TECHNICAL SUPPORT SERVICE SO THAT THEY CAN REPLACE IT (Only an original spare part can be used since the glass has special properties)

9. PROBLEMS, MESSAGES, ERRORS AND SOLUTIONS

The heater uses messages and alarms that appear on the display to inform the user of certain situations and/or problems that hinder the correct operation of the unit.

The electronic control board, via various devices and sensors connected to it, receives data. It returns a message or alarm when the values fall outside certain ranges.

This does not mean that the heater has a problem, but rather, on many occasions, it brings issues to light regarding the fuel, installation, lack of cleaning, or something else.

Carefully read everything that is explained in this section because as well as helping you to interpret the messages and alarms that may be shown, it lists possible causes and even some remedial measures that can be taken.



THE APPEARANCE OF MESSAGES AND ALARMS IS PART OF NORMAL OPERATION BECAUSE THEY SERVE TO NOTIFY THE USER OF SPECIFIC SITUATIONS. THEY ONLY POINT TO A PROBLEM WITH THE HEATER WHEN THEY ARE CAUSED BY THE DEFECTIVE OPERATION OF ONE OR MORE OF THE COMPONENTS OF THE HEATER THAT HAVE LEFT THE FACTORY IN A DEFECTIVE CONDITION

9.1 PROBLEMS

Some advice appears below so that you can make sure that everything is correct before lighting the heater and assuredly begin the start-up process:

- Check that the installation has been effected in accordance with any regulations in force and in accordance with the instructions from the manufacturer. (see chapter 5. INSTRUCTIONS FOR INSTALLATION).
- Only use fuel that is appropriate and try to keep the level in the hopper to half-full, at minimum. (see chapter 4. FUEL).
- If the fuel has spent a long time in the hopper, it is appropriate to remove it because it could have absorbed moisture from the air and no longer be suitable for use. If damp wood pellets are used, they could affect the normal operation of the heater.
- Carry out the maintenance instructed by the manufacturer, not forgetting to clean the brazier every 10-12 hours (at most) of operation. After cleaning, replace it correctly.

When the heater functions improperly, an alarm or message will normally appear, although this will not always occur. Below, we show some cases that could arise and some checks that it would be useful to do before calling the Technical Support Service:

- When the heater is connected, the breaker in the house is tripped. The first step would be to try connecting the heater to another plug. If the problem continues, there could be a moisture issue with one or more of the components inside the heater. In this case, make sure that the heater is not being affected by moisture in the environment and/or chimney and wait for a few hours before trying to light it again. If the problem persists, call the Technical Support Service.
- The display fails to turn on. Check that the voltage at the plug is correct, see if the rear switch is turned on, the fuse in the switch may be blown, etc.



ON DAYS WITH STRONG WINDS OR ADVERSE WEATHER CONDITIONS, IT IS POSSIBLE THAT COMBUSTION IN THE HEATER IS NOT IDEAL DUE TO THE CHIMNEY FLUE BEING AFFECTED. THE MANUFACTURER IS NOT LIABLE FOR THE POOR OPERATION OF THE HEATER UNDER ADVERSE WEATHER CONDITIONS

9.2 MESSAGES

MESSAGE	DESCRIPTION OF THE MESSAGE	SOLUTION
Sond	Visualisation of the state of the temperature sensors or flow sensor. The message appears during the 'Check-up' phase and indicates whether or not the temperature and air flow detected are between the minimum and maximum values allowed	<ul style="list-style-type: none"> • Check the status and the connection of the sensors • Notify the Technical Support Service if the message persists.
Hi	This indicates that the room temperature is in excess of 50 °C	<ul style="list-style-type: none"> • Check the status and the connection of the temperature sensor. • Notify the Technical Support Service if the issue does not resolve itself.
CLr	This message indicates that a certain number of hours have passed and maintenance is required for the heater	<ul style="list-style-type: none"> • Notify the Technical Support Service so that they can perform extraordinary cleaning and reset the service hours counter.
OFF dEL	This message appears when the heater has been turned of automatically during the lighting phase (after the pre-loading stage). The unit turns itself off once returning to operate at full capacity.	
PCLr	Automatic self-cleaning of the burner that is performed by the heater during operation	<ul style="list-style-type: none"> • No action is required, after the time required for this cleaning process has passed, the message will disappear

9.3 ERRORS AND SOLUTIONS

CODE ALARM	DESCRIPTION	POSSIBLE CAUSE	SOLUTION
Er01	Intervention of the safety thermostat	<ul style="list-style-type: none"> • Safety thermostat or cable broken • Excessive temperature in the hopper 	Notify the Technical Support Service
Er02	Intervention of the safety pressure switch	<ul style="list-style-type: none"> • The chimney is very dirty or blocked 	Check and clean out the chimney
		<ul style="list-style-type: none"> • Chimney experiencing excessive loss of load: extended horizontal stretch, excessive length, insufficient diameter, too many elbows, etc. 	Review and correct the installation
		<ul style="list-style-type: none"> • Back-puffing of smoke caused by the wind 	Review the orientation of the smoke outlet and make sure that the cowl installed is appropriate.
		<ul style="list-style-type: none"> • Issue with the pressure switch or its connection with the electronic control board 	If the alarm continues to appear when you attempt to start the unit after having reviewed and corrected all of the above, notify the Technical Support Service
Er03	Turning-off due to the temperature of the smoke	<ul style="list-style-type: none"> • There are too few wood pellets in the hopper 	Pour more wood pellets into the hopper and reset the error
		<ul style="list-style-type: none"> • A 'cave' has formed in the hopped and no wood pellets are reaching the loading screw 	Make sure that the wood pellets are reaching the wood screw (dismantle the cave), pour more wood pellets into the wood hopper if necessary.
		<ul style="list-style-type: none"> • The loading screw has become stuck and/or the loading motor is not spinning 	If no wood pellets fall into the burner after trying several times to turn the unit on, notify the Technical Support Service

ALARM CODE	DESCRIPTION	POSSIBLE CAUSE	SOLUTION
Er05	Turning-off due to the excessive temperature of the smoke	<ul style="list-style-type: none"> The room is too warm 	Check the desired room temperature and that the temperature sensor is correctly located to detect the temperature in the room
		<ul style="list-style-type: none"> The room fan is not working or does so very slowly 	In the event that this alarm repeats frequently or cannot be turned off, notify the Technical Support Service
		<ul style="list-style-type: none"> No smoke sensor or it has broken. In this case, 'Hi' would appear in the information about the smoke temperature 'tF' and the room fan would operate at maximum speed. 	
Er07	The electronic control board is not receiving any signal from the smoke extraction speed controller.	<ul style="list-style-type: none"> This could appear due to fluctuations in the mains electrical grid 	Reset the error and turn the unit on again. This error will then disappear and the unit will enter safety operation. Notify the Technical Support Service. Meanwhile, the unit can be used. If this situation occurs again, it is advisable to install an uninterruptible power supply (UPS)
		<ul style="list-style-type: none"> The smoke fan and/or one of its connections are broken 	
Er08	The speed of the smoke extraction fan cannot be properly adjusted	<ul style="list-style-type: none"> This could appear due to fluctuations in the mains electrical grid 	Reset the error and turn the unit on again If this situation occurs again, it is advisable to install an uninterruptible power supply (UPS)
		<ul style="list-style-type: none"> The voltage from the mains power supply is not appropriate or proceeds from a generator of non-sinusoidal alternating current. 	Make sure that the unit is connected to a suitable power supply
		<ul style="list-style-type: none"> The smoke fan and/or one of its connections are broken 	Reset the error and turn the unit on again. This error will then disappear and the unit will enter safety operation. Notify the Technical Support Service. Meanwhile, the unit can be used.
Er11	Update DATE and TIME	<ul style="list-style-type: none"> This could appear the first time that the heater is connected to the mains power supply or after several days disconnected. 	To update the time and day of the week, see section 6.2.3

CODE ALARM	DESCRIPTION	POSSIBLE CAUSE	SOLUTION
Er12	Failure at start-up	<p>IF THE BRAZIER IS PRACTICALLY EMPTY</p> <ul style="list-style-type: none"> • There are few wood pellets in the hopper • A 'cave' has formed in the hopped and no wood pellets are reaching the loading screw • The loading screw has become stuck and/or the loading motor is not spinning 	<p>Reset the error Make sure that the wood pellets can reach the screw and/or pour in more if necessary If no wood pellets fall into the burner after trying several times, notify the Technical Support Service</p>
		<p>IF THE BRAZIER IS FULL OF WOOD PELLETS (unburned)</p> <ul style="list-style-type: none"> • Damp or poor-quality wood pellets • Ignition coil and/or connecting cable are broken 	<p>Empty and clean the brazier, reset the alarm, and try to start it up again Check the condition and quality of the wood pellets If the unit does not ignite after two or three attempts, call the Technical Support Service</p>
Er15	Electrical power supply cut	<ul style="list-style-type: none"> • The power supply has been cut for an extended period of time whilst the heater is operating or during ignition 	<p>Reset the error and turn the unit on again In the event that this alarm repeats frequently or cannot be turned off, notify the Technical Support Service</p>
Er17	Impossible to regulate the air flow	<ul style="list-style-type: none"> • There could be an issue with the smoke outlet • The air inlet could be partially or fully blocked, or has become channelled and a lot of load is being lost • Dirty brazier • The heater is taking in air from an unexpected inlet: open or poorly closed door, hopper empty of wood pellets etc. • The smoke ducts inside the heater are very dirty • The smoke extractor has lost power • Problems with the flow sensor or its connection (the Sond message will appear) • Broken air flow sensor 	<p>Review all the possibilities mentioned for Er02 Check the heater and the installation Check the cleanliness of the heater and the smoke outlet In the event that this alarm repeats frequently or cannot be turned off, notify the Technical Support Service</p>
Er39	Broken flow measurement sensor	<ul style="list-style-type: none"> • This could appear when the heater is turned off during operation or if the flow sensor breaks 	<p>If this problem persists, Er41 will appear</p>

CODE ALARM	DESCRIPTION	POSSIBLE CAUSE	SOLUTION
Er41	The minimum air flow was not reached during the 'Check-up' stage	<ul style="list-style-type: none"> • There could be an issue with the smoke outlet • The air inlet could be partially or fully blocked, or has become channelled and a lot of load is being lost • Dirty brazier • The heater is taking in air from an unexpected inlet: open or poorly closed door, hopper empty of wood pellets etc. • The smoke ducts inside the heater are dirty • The smoke extractor has lost power • Problems with the flow sensor or its connection (the Sond message will appear) 	<p>Review all the possibilities mentioned for Er02</p> <p>Check the heater and the installation</p> <p>Check the cleanliness of the heater and the smoke outlet</p> <p>In the event that this alarm repeats frequently or cannot be turned off, notify the Technical Support Service</p>
Er42	Excessive air flow during the 'Check-up' stage	<ul style="list-style-type: none"> • This could occur if the chimney flue is excessive or if air is being forced in for combustion. 	<p>Review and correct the installation</p> <p>In the event that this alarm repeats frequently or cannot be turned off, notify the Technical Support Service</p>

With the help of this table of alarms, the user is able to locate the reason behind the error that has occurred. Once the aforementioned cause has been found and corrected, the alarm must be reset to allow the heater to be turned on again.



RESETTING THE ALARMS:

- When any alarm is generated the heater will turn itself off.
- The alarm cannot be reset until the heater is fully turned off.
- Once turned off, it is necessary to wait until 'Alt' appears on the upper display and then long press  so that the active alarm is reset.
- Once the alarm has been reset, it is advisable to turn off the heater for a few seconds with the rear switch.

ANNEXED

ASSEMBLING THE TABLE WITH LEGS AT DIFFERENT HEIGHTS

The installation of the table (accessory) with the ULYSES pellet insert is easy and simple. The user has to unscrew the 5 tri-lobe screws that are screwed to the table as indicated in the figures below. Subsequently, the base of the insertable is placed on the table, matching the 5 holes to then screw it onto the table with the 5 screws that we have unscrewed in the previous step.

This way, the base of the insert would be mounted on the table, it would only be left to then put the insert on the base that we have screwed to the table of different heights.

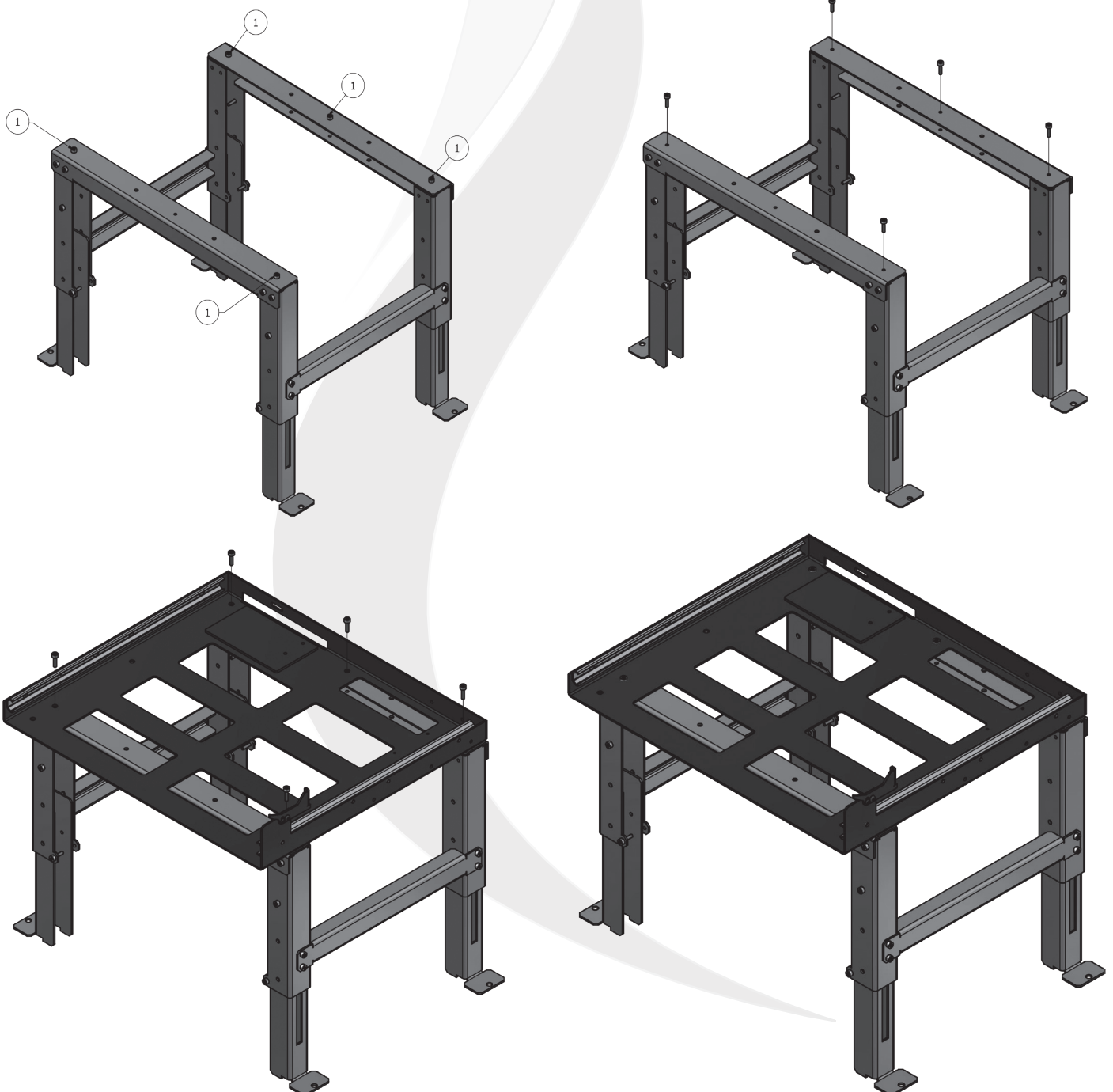

REGULATION OF THE LEGS AT DIFFERENT HEIGHTS

We can adjust the table to the height we need, this is done very easily, as indicated in the diagrams below, unscrew the screws, place it at the height we want, matching the holes to screw back at that height.

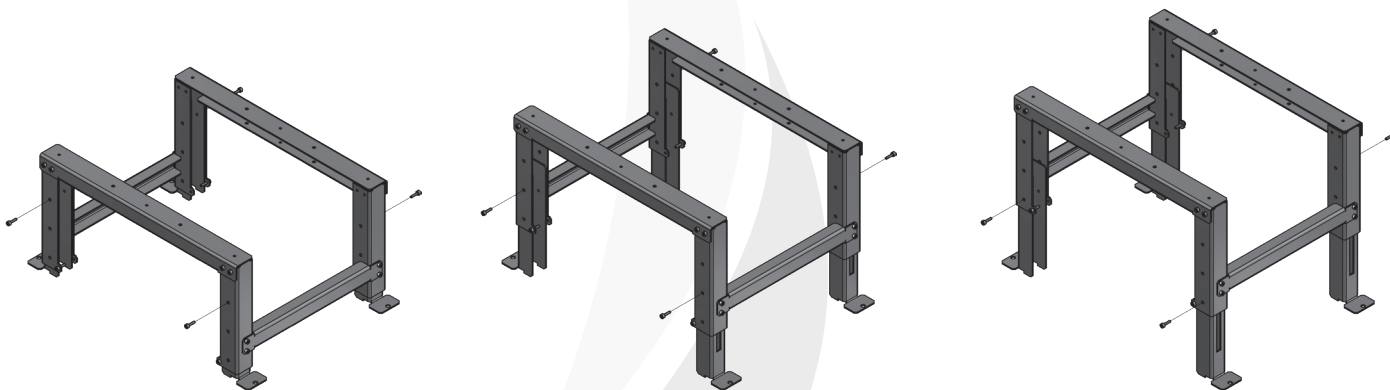

MOUNTING ADDITIONAL CHARGING TUBE ON INSERTABLE

Another of the accessories that our insertable line consists of is the load chute for the pellet.

For the installation of this accessory we are going to put a graphic representation so that the assembly steps are followed. That is, first we place Fig. 1 on the cover of the insert, then we place Fig. 2 and screw to the base of the insert and to Fig. 1, then we repeat this step with Fig. 3

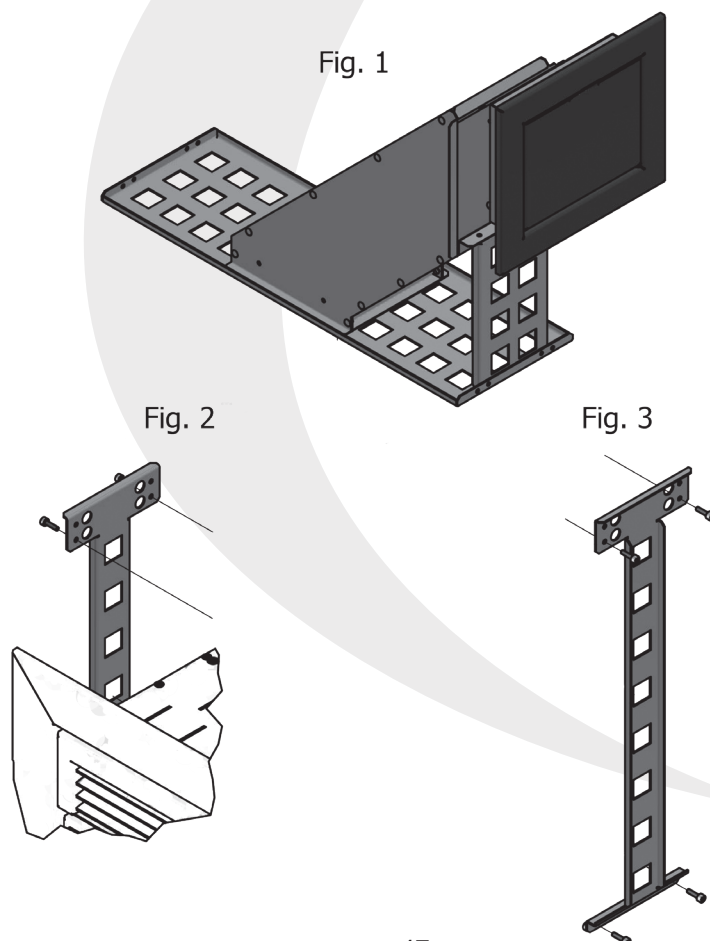
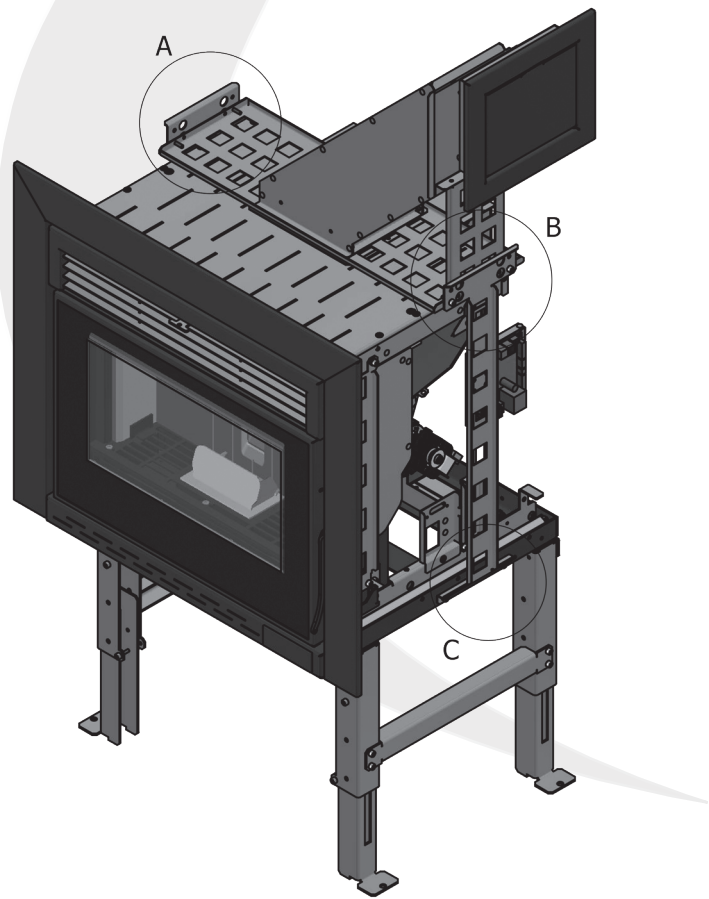
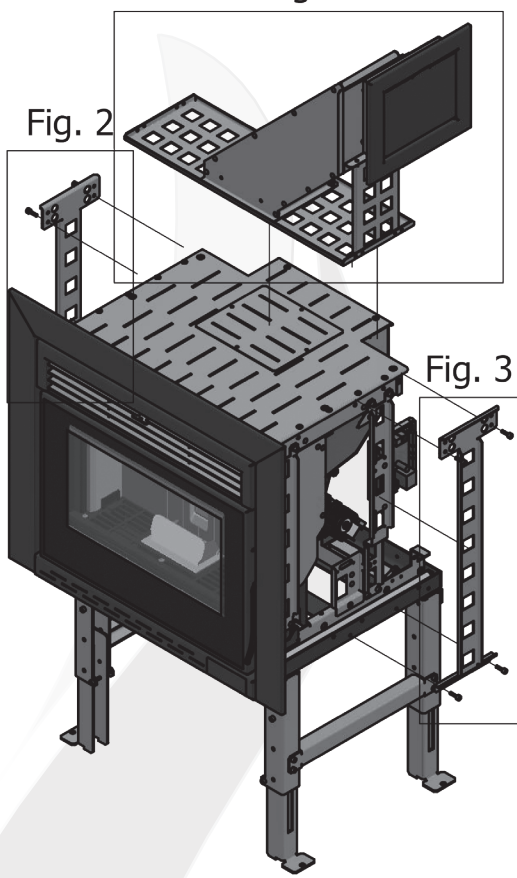

Fig. 1



ASSEMBLY OF ADDITIONAL CHARGING TUBE IN CLADDING

Once we have assembled the structure and the additional downpipe on the device, we go to the next step, which would be to adjust the additional telescopic tube and fix it on the cladding of our installation.

We proceed to disassemble the filler neck as indicated in the following image.

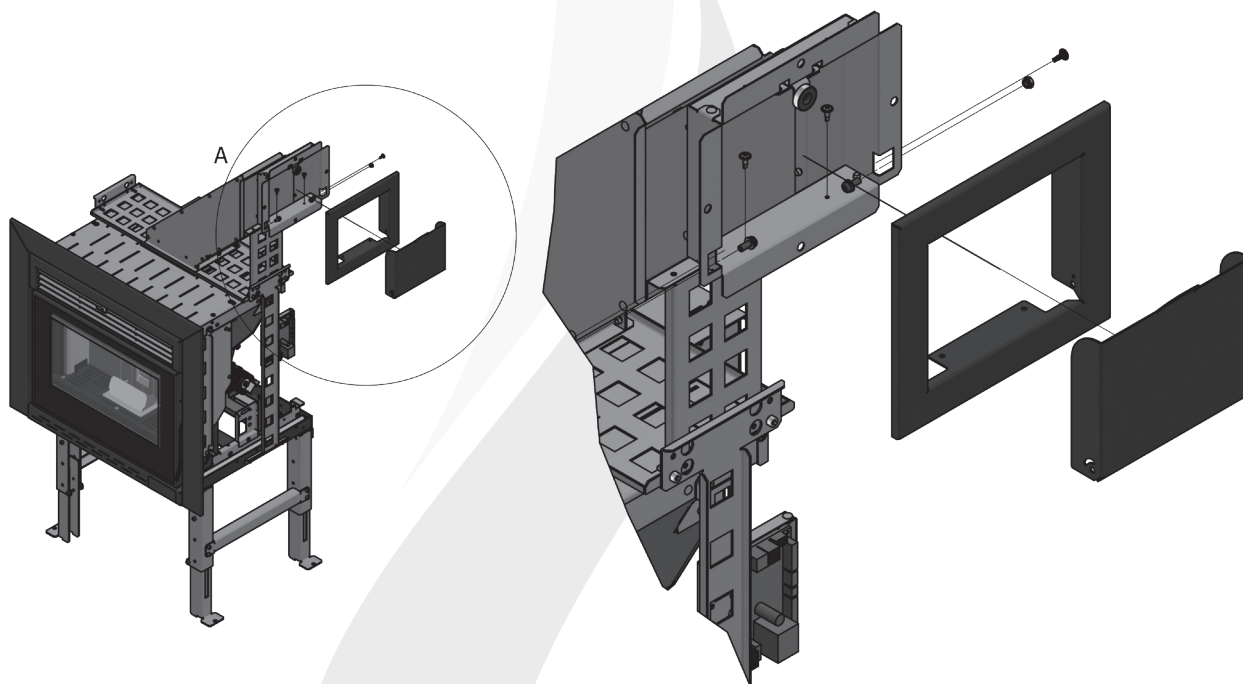

Once we have disassembled the filler neck and the trim, we proceed to fix the structure of the downspout in the lining of our installation, as indicated in the figure below.

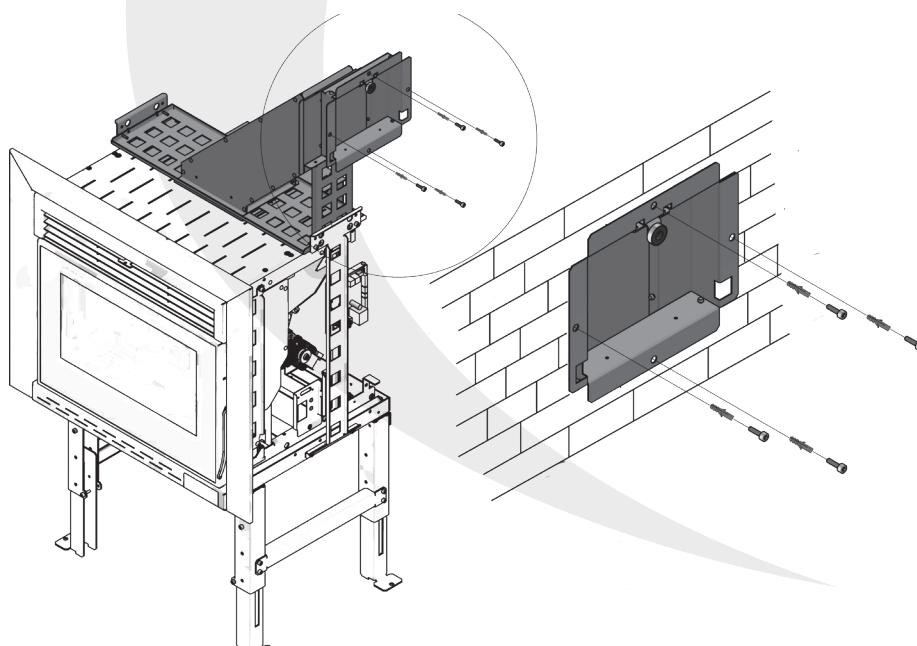

CERTIFICADO DE GARANTÍA
COMMERCIAL WARRANTY

Nº _____

La presente Garantía Comercial se otorga sin perjuicio además de cualesquiera de los derechos reconocidos por la Ley 23/2003 y RDL 1/2007 frente al vendedor.
 Para ejercitar sus derechos de conformidad con esta Garantía Comercial, el comprador deberá rellenar este certificado en el punto de venta en el momento de la compra y presentarlo junto con la factura, ticket de compra o albarán de entrega.
 A presente *Garantía Comercial é concedida sem prejuizo de qualquer um dos direitos reconhecidos pela Lei 23/2003 e RDL 1/2007 ao vendedor.*
 Para exercer os seus direitos em conformidade com esta *Garantía Comercial, o comprador deverá preencher este certificado no ponto de vendas no momento da compra e apresentá-lo juntamente com a fatura, talão de compra ou nota de entrega.*
 This Commercial Warranty does not in any way affect the purchaser's rights in respect of the vendor as set forth in [Spanish] Act. 23/2003 and 1/2207.
 The purchser must complete this certificate at the point of sale at the time of purchase and must present it together with the invoice, purchase slip or delivery note in order to exercise his or her rights under this Commercial Warranty.
 La présente *Garantie Commerciale est octroyée sans préjudice en plus de tous droits reconnus par la Loi 23/2003 et RDL 1/2007 auprès du vendeur.*
 Pour exercer ses droits en conformité avec cette *Garantie Commerciale, lâcheteur devra remplir ce certificat sur le point de vente au moment de lâchat et le présenter joint à la facture, ticket d'achat ou bon de livraison.*

Fecha de compra (comienzo de la garantía) / Data de compra (inicio da garantia) / purchase date (beginning of the warranty) / Date de l'achat (début de la garantie).....

COMPRADOR / COMPRADOR / PURCHASER / ACHETEUR

Nombre / nome / name / nom.....
 Dirección / endereço / mailing address / adresse.....
 Código postal / codigo postal / post code code postal.....
 Población / cidade / city / ville.....
 Teléfono / telefone / telephone / téléphone.....
 País / pais / country / pays.....

VENDEDOR / VENDEDOR / SELLER / VENDEUR

Sello del vendedor / Carimbo do vendedor / Seller stamp / Tampon du vendeur:

Denominación del aparato / Denominação do aparelho / Equipment name / Dénomination de l'appareil.....
 Referencia / Referência / Reference / Référence.....

CERTIFICADO A DEVOLVERNOS DENTRO DE LOS 10 DÍAS SIGUIENTES A LA COMPRA
ESTE CERTIFICADO DEVER A SER NOS ENVIADO NO ESPAÇO DE 10 DIAS A SEGUIR A DATA DA COMPRA
CERTIFICATE TO RETURN US WITHIN TEN DAYS FOLLOWINGS THE PURCHASE
CE CERTIFICAT DEVRA NOUS ÊTRE RENVOYE DANS LES 10 JOURS SUIVANTS LA DATE DE L'ACHAT

Fecha de compra (comienzo de la garantía) / Data de compra (inicio da garantia) / purchase date (beginning of the warranty) / Date de l'achat (début de la garantie).....

COMPRADOR / COMPRADOR / PURCHASER / ACHETEUR

Nombre / nome / name / nom.....
 Dirección / endereço / mailing address / adresse.....
 Código postal / codigo postal / post code code postal.....
 Población / cidade / city / ville.....
 Teléfono / telefone / telephone / téléphone.....
 País / pais / country / pays.....

VENDEDOR / VENDEDOR / SELLER / VENDEUR

Sello del vendedor / Carimbo do vendedor / Seller stamp / Tampon du vendeur:

Denominación del aparato / Denominação do aparelho / Equipment name / Dénomination de l'appareil.....
 Referencia / Referência / Reference / Référence.....

MUY IMPORTANTE	MUITO IMPORTANTE	VERY IMPORTANT	TRES IMPORTANT
<p>La garantía sólo es válida:</p> <ul style="list-style-type: none"> • Si se respetan las reglas contractuales • Si el presente certificado está rellenado correctamente y si se ha devuelto dentro de los diez días siguientes a la fecha de compra 	<p>A garantia só é válida:</p> <ul style="list-style-type: none"> • Se as regras contratuais forem respeitadas. • Se o presente certificado estiver correta e totalmente preenchido e tiver sido devolvido no espaço de dez dias a contar da data de compra. 	<p>The guarantee is only valid:</p> <ul style="list-style-type: none"> • If the contractual rules are respected. • If the present certificate is filled correctly and completely and if it is returned within the ten days after the purchase date. 	<p>La garantie est uniquement valable:</p> <ul style="list-style-type: none"> • Si les règles contractuelles sont respectées. • Si e présent certificat est correctement est entièrement rempli et s'il a été renvoyé dans les dix jours qui suivent la date de l'achat.



CONDICIONES GENERALES DE ESTE CONTRATO DE GARANTÍA COMERCIAL

1º La presente Garantía Comercial ofrece la reparación gratuita de cualquier avería por defecto de fabricación en el Servicio Técnico Autorizado, incluyendo la mano de obra y piezas de recambio. Sólo estamos obligados al cambio gratuito de los elementos reconocidos defectuosos después de haberlos inspeccionado y controlado por nuestro personal técnico y siempre que no hayan concurrido ninguna de las exclusiones de la garantía. Si el cambio de estos elementos resultase muy oneroso, la reparación efectuada no fuera satisfactoria y el objeto no revistiese las condiciones óptimas para cumplir el uso a que se estuviese destinado, el titular de la garantía tendrá derecho a la sustitución del objeto adquirido por otro de idénticas características o la devolución del precio pagado.

2º El plazo de validez, contado a partir de la fecha de compra es de: Dos años para los componentes distintos de la fundición, tales como, tornillería, resortes, ventiladores, circuitos impresos, interruptores, terminales, hilos eléctricos, funda eléctrica, etc.

3º La Garantía no será válida si no va acompañada de la correspondiente factura de compra debidamente rellena y sellada por el establecimiento vendedor autorizado.

4º La Garantía solo es válida si el producto se utiliza según las reglas y recomendaciones indicadas en las instrucciones para la instalación y uso suministradas con la estufa o chimenea, que el comprador reconoce haber recibido y acepta ajustarse a las mismas para su seguridad.

5º Exclusiones:

- Esta Garantía no Incluye el cristal de la estufa, el cual ha sido sometido a una serie de pruebas y test de calidad durante el proceso de fabricación, quedando probada su durabilidad y resistencia, soportando una temperatura de 750°, la cual nunca ha sido alcanzada en la cámara de combustión, por lo que queda dicho elemento totalmente excluido de la garantía en el caso de ruptura, solo posible por mala manipulación en el uso o manejo de la estufa.
- Tampoco están incluidas en la garantía las juntas, que son consideradas como piezas de desgaste, así como las piezas del hogar en contacto directo con el combustible en ignición, tales como, brasero, deflector, piezas de vermiculita, resistencia de encendido, etc.
- Los daños producidos por el uso de cualquier otro combustible distinto del pellets que no serán cubiertos por la garantía.
- Esta garantía no incluye las instalaciones, las puestas en marcha, las roturas, instalación incorrecta, voltaje inadecuado o descargas atmosféricas (rayo), así como manipulaciones por personas o talleres no autorizados.
- El hecho de superar la carga por hora indicada en este manual y la instalación; anula la garantía de este equipo eximiendo al fabricante de cualquier responsabilidad.

6º La presente Garantía Comercial es válida en las condiciones indicadas durante los plazos señalados anteriormente.

FERLUX no se hace responsable en ningún caso de eventuales daños producidos a personas o cosas por manipulación indebida del aparato o por mal uso.

En todo caso, el titular de la garantía tiene todos los derechos mínimos reconocidos por la Ley.

7º FERLUX se reserva el derecho a modificar este manual sin preaviso.

8º Para ejercitar los derechos conforme a esta Garantía Comercial, el consumidor dispone de las siguientes vías de reclamación:

- E-mail: ferlux@ferlux.es
- Web: www.ferlux.es
- Dirección: Polígono el Polear, parc. 1 C.P.: 29313 Villanueva del Trabuco (MÁLAGA)

GENERAL CONDITIONS OF THIS COMMERCIAL WARRANTY AGREEMENT

1º This Commercial Warranty covers the free repair of any failure due to defective manufacture at the Official After-Sales Service, including labour and parts (the staff trip of the Authorized Technical Service is not included). Our liability is limited to free replacement of the parts that are acknowledged to be defective after inspection and checking that none of the exclusions are applicable. Should replacement of these parts prove highly onerous, or should the repair effected not prove satisfactory and the object not be in perfect condition for its intended use, the warranty holder shall be entitled to replacement of the object purchased by another of identical characteristics or to a refund of the purchase price.

2º The warranty period, commencing on the date of purchase is: Two years for parts other than cast iron, such as bolts, springs, fans, circuit boards, switches, terminals, electrical wires, electrical sheathing, etc.

3º The Warranty shall not be valid unless accompanied by proof of purchase duly completed and stamped by the authorised vendor.

4º The Warranty is only valid if the product is used in accordance with the rules and recommendations given in the instructions for installation and use supplied with the stove or chimney, which the purchaser acknowledges having received and agrees to follow for his or her own safety.

5º Exclusions:

- This Warranty does not include the glass of the stove, which has been subjected to a series of tests and quality testing at the factory that have proved its durability and resistance, including subjecting it to a temperature of 750°, which has never been reached in the combustion chamber. Consequently, this part is totally excluded from the warranty in the event of breakage, which can only be caused by poor use or handling of the stove.
- Gaskets are also excluded from the warranty as they are considered parts subject to wear, as are the parts of the fireplace in direct contact with the burning fuel such as the brazier, deflector, vermiculite parts, ignition resistance, etc.
- Damage caused by the use of any fuel other than wood is not covered by the Warranty.
- The Warranty does not include installations, start-ups, breakages, incorrect installation, unsuitable voltage or atmospheric discharge (lightning), or handling by unauthorised persons or businesses.
- The fact to overcome the burden of time indicated in this manual and the installation of these models, void the warranty of this equipment exempt the manufacturer from any liability.

6º This Commercial Warranty is valid under the aforesaid conditions for the above-stated periods.

In no case shall FERLUX be liable for any damage caused to persons or things by improper handling or use of the appliance.

In all cases the warranty holder shall have all the minimum rights provided in law.

7º FERLUX reserves the right to make any modification in the manual without prior warning.

8º Consumers wishing to exercise their rights under this Commercial Warranty may lodge claims by any of the following means:

- E-mail: ferlux@ferlux.es
- Web: www.ferlux.es
- Dirección: Polígono el Polear, parc. 1 C.P.: 29313 Villanueva del Trabuco (MÁLAGA)

CLEANING AND MAINTENANCE

PERIODIC INSPECTION AND MAINTENANCE

DATE PERIODIC REVISION:/...../.....

SEAL AND FIRM

CLEANING AND MAINTENANCE

PERIODIC INSPECTION AND MAINTENANCE

DATE PERIODIC REVISION:/...../.....

SEAL AND FIRM

CLEANING AND MAINTENANCE

PERIODIC INSPECTION AND MAINTENANCE

DATE PERIODIC REVISION:/...../.....

SEAL AND FIRM

CLEANING AND MAINTENANCE

PERIODIC INSPECTION AND MAINTENANCE

DATE PERIODIC REVISION:/...../.....

SEAL AND FIRM

CLEANING AND MAINTENANCE

PERIODIC INSPECTION AND MAINTENANCE

DATE PERIODIC REVISION:/...../.....

SEAL AND FIRM

CLEANING AND MAINTENANCE

PERIODIC INSPECTION AND MAINTENANCE

DATE PERIODIC REVISION:/...../.....

SEAL AND FIRM

CLEANING AND MAINTENANCE

PERIODIC INSPECTION AND MAINTENANCE

DATE PERIODIC REVISION:/...../.....

SEAL AND FIRM

CLEANING AND MAINTENANCE

PERIODIC INSPECTION AND MAINTENANCE

DATE PERIODIC REVISION:/...../.....

SEAL AND FIRM

CLEANING AND MAINTENANCE

PERIODIC INSPECTION AND MAINTENANCE

DATE PERIODIC REVISION:/...../.....

SEAL AND FIRM



Chimeneas y Barbacoas FERLUX, S.A.

Parque Empresarial El Polear, Parc. 1
29313 Villanueva del Trabuco MÁLAGA (España)

www.ferlux.es / e-mail: ferlux@ferlux.es



Management
System
ISO 9001:2008

www.tuv.com
ID 9105025453